

# An analysis of loop checking mechanisms for logic programs\*

Roland N. Bol

*Centre for Mathematics and Computer Science, P.O. Box 4079, 1009 AB Amsterdam, Netherlands*

Krzysztof R. Apt

*Centre for Mathematics and Computer Science, P.O. Box 4079, 1009 AB Amsterdam, Netherlands*

Jan Willem Klop

*Centre for Mathematics and Computer Science, P.O. Box 4079, 1009 AB Amsterdam, Netherlands, and Department of Computer Sciences, Free University of Amsterdam, De Boelelaan 1081, 1081HV Amsterdam, Netherlands*

## *Abstract*

Bol, R.N., K.R. Apt and J.W. Klop, An analysis of loop checking mechanisms for logic programs, *Theoretical Computer Science* 86 (1991) 35–79.

We systematically study loop checking mechanisms for logic programs by considering their soundness, completeness, relative strength and related concepts. We introduce a natural concept of a *simple loop check* and prove that no sound and complete simple loop check exists, even for programs without function symbols. Then we introduce a number of sound simple loop checks and identify natural classes of Prolog programs without function symbols for which they are complete. In these classes a limited form of recursion is allowed. As a by-product we obtain an implementation of the closed world assumption of Reiter (1978) and a query evaluation algorithm for these classes of logic programs.

## **1. Introduction**

### *1.1. Motivation*

Prolog has been advocated as a programming language which allows us to write executable specifications. Unfortunately, when interpreting correct specifications written in the form of a logic program as a Prolog program, a divergence usually

\* This research was partly supported by Esprit BRA-project 3020 Integration.

arises. This is due to the fact that the Prolog interpreter uses a depth-first search and consequently can enter an infinite branch and miss a solution.

The problem of detecting such a possibility of divergence is obviously undecidable as Prolog has the full power of recursion theory. Consequently this problem has been taken care of by developing a number of useful heuristics on how to avoid a possibility of nontermination. However, the resulting program can be very different from the original specification.

Another possible approach to this problem has been based on modifying the underlying computation mechanism that searches through the corresponding SLD-trees by adding a capability of pruning. Pruning an SLD-tree means that at some point the interpreter is forced to stop its search through a certain part of the tree, typically an infinite branch. Every method of pruning SLD-trees considered so far has been based on excluding some kind of repetition in the SLD-derivations, because such a repetition makes the interpreter enter an infinite loop. That is why pruning SLD-trees has been called *loop checking*. Such modifications of Prolog interpreters were considered in the literature (see e.g. [3, 4, 8, 18, 20, 21, 23]), but no results were proved about them, with notable exceptions of [20, 21, 23].

## 1.2. Plan of the paper

In this paper we systematically study loop checking mechanisms. To this end, after providing in Section 2 a sufficiently general definition of a loop check, we introduce in Section 3 the relevant concepts, like soundness (no computed answer substitution to a goal is missed), completeness (all resulting derivations are finite) and relative strength. We also introduce a natural subclass of loop checks, called *simple* loop checks, obtained when their definition does not depend on the analyzed logic programs. We prove among others the result that no sound and complete simple loop check exists even in the absence of function symbols.

In the remainder of the paper we study a number of intuitive simple loop checks. We can divide them into three groups, which are studied in Sections 4, 5 and 6 respectively. For each group we prove the appropriate soundness results and identify one or more natural classes of programs without function symbols for which the loop checks in the group are complete. The loop checks in all three groups appear to be complete for *restricted* programs without function symbols. Restricted programs allow a restricted form of recursion (hence the name).

The first group consists of loop checks based on the *equality* between goals, respectively resultants, of the derivations and is studied in Section 4. We call these loop checks *equality checks*.

The second group of loop checks is based on the *inclusion* between goals, respectively resultants, of the derivations and is studied in Section 5. We call these loop checks *subsumption checks*. Subsumption checks are stronger than the corresponding equality checks and therefore they prune SLD-derivations earlier than their counterparts. This makes it more difficult to establish their soundness but

opens a possibility for completeness for a larger class of programs than restricted ones.

We show that subsumption checks are complete for logic programs without function symbols in which no variables are introduced in the clause bodies (so called *nvi programs*). Also, the subsumption checks are complete for logic programs without function symbols in which a variable occurs at most once in every clause body (so called *svo programs*). These completeness theorems make use of a simple version of Kruskal's Tree Theorem, called Higman's Lemma [12]. While the use of this theorem to establish termination of term rewriting systems is well-known (see e.g. [9] or [14]), we have not encountered any applications of this theorem in the area of logic programming.

The third group is based on a simple loop check introduced by Besnard [3] and is studied in Section 6. These checks test for equality of atoms in a certain context (a goal or a resultant). Therefore we call them *context checks*. We prove that for certain selection rules, the subsumption checks are stronger than the context checks.

As mentioned above, we prove that context checks are complete for restricted programs without function symbols. We also prove that the context checks are complete for *nvi* programs without function symbols.

### 1.3. Example

To better understand the relevance of the problems studied here, consider the following example. Let  $P$  be the following simple-minded Prolog program computing in the relation  $tc$  the transitive closure of the relation  $r$ :

$$P = \{ tc(x, y) \leftarrow r(x, y), \\ tc(x, y) \leftarrow r(x, z), tc(z, y). \}$$

Suppose we add to  $P$  the following facts about  $r$ :  $r(a, a) \leftarrow$ ,  $r(a, b) \leftarrow$ ,  $r(b, c) \leftarrow$ ,  $r(d, a) \leftarrow$ . Then if we ask:

- $tc(a, b)$ , we get the answer "yes";
- $tc(a, c)$ , the program gets into an infinite loop (whereas we should get the answer "yes");
- $tc(a, d)$ , the program gets into an infinite loop (whereas we should get the answer "no");
- $tc(b, d)$ , we get the answer "no".

Thus  $P$  is not the right program for computing the transitive closure. One solution is to write a different program, which is not straightforward, see for example the program in [7, Section 7.2]. In fact, Kunen [15] recently proved that any such program must use either function symbols or negated literals.

In our solution, we change the underlying interpreter by adding to it an equality check, and retain the above program, which turns out to be restricted. (In contrast, this solution cannot be applied to an alternative version of  $P$  obtained by replacing

the second clause by  $tc(x, y) \leftarrow tc(x, z), tc(z, y)$ , as the resulting program is in that case not restricted.)

#### 1.4. Applications

As a by-product of these considerations we obtain an implementation of the *closed world assumption* of Reiter [19] and of a query evaluation mechanism for various classes of definite deductive databases. The closed world assumption (CWA in short) is a way of inferring negative information in deductive databases. Reiter [19] showed that in the case of definite deductive databases (DB in short) it does not introduce inconsistency. However, even though CWA is correctly defined for DB, there is still the problem of how it can be implemented, since it calls for the use of the following rule (or rather metarule):

$$\text{if } DB \not\vdash \varphi \text{ then } DB \vdash \neg\varphi,$$

that is, deduce  $\neg\varphi$  if  $\varphi$  cannot be proved from DB using first order logic.

The problem is how to determine for a particular ground atom (or *fact* in short) that there is no proof of it. The soundness and completeness results proved in Section 4 show that when DB is a restricted program, to infer  $\neg A$  for a fact  $A$  it suffices to use Clark's [5] *negation as (finite) failure* rule augmented with an appropriate equality check.

A more general problem is that of query processing in DB. Given an atom  $A$ , compute the set  $[A]_{DB}$  of all its ground instances  $A\theta$  such that  $DB \vdash A\theta$ . Indeed, when  $A$  is ground and  $DB \not\vdash A$ , the query processing problem reduces to the problem of deducing  $\neg A$  by means of CWA. The results proved in Section 4 imply that when DB is a restricted program, to compute  $[A]_{DB}$  for an atom  $A$ , it suffices to collect all computed answer substitutions in the SLD-tree with leftmost selection rule and  $\leftarrow A$  as root, pruned by an appropriate equality check.

Similar results concerning CWA and query processing hold for the subsumption and context checks and the corresponding classes of programs for which they are complete.

This paper is an extension of [1], where exclusively equality checks were studied.

## 2. Loop checking

Throughout this paper we assume familiarity with the basic concepts and notations of logic programming as described in [16]. For two substitutions  $\sigma$  and  $\tau$ , we write  $\sigma \leq \tau$  when  $\sigma$  is more general than  $\tau$  and for two expressions  $E$  and  $F$ , we write  $E \leq F$  when  $F$  is an instance of  $E$ . We then say that  $F$  is *less general* than  $E$ .

By an SLD-derivation we mean an SLD-derivation in the sense of [16] or an *initial segment of it*. In SLD-derivations we shall only use idempotent mgu's. It is known that any idempotent mgu is *relevant*, i.e. its domain contains only variables

of the atoms that are unified. An SLD-derivation step from a goal  $G$ , using a clause  $C$  and an idempotent mgu  $\theta$ , to a goal  $H$  is denoted as  $G \Rightarrow_{C,\theta} H$ .

### 2.1. Definitions

The purpose of a loop check is to prune every infinite SLD-tree to a finite subtree of it containing the root. One might define a loop check as a function from SLD-trees to SLD-trees, directly giving the pruned tree. However, this would be a very general definition, allowing practically everything. We shall use here a more restricted definition according to which for a program  $P$

(i) a node in an SLD-tree of  $P \cup \{G\}$  (for some goal  $G$ ) is *pruned* if all its descendants have been removed (note the terminology: the pruned node itself remains in the tree);

(ii) by pruning some of the nodes we obtain a pruned version of the SLD-tree;

(iii) whether a node is pruned depends only upon its ancestors in the SLD-tree, that is on the SLD-derivation from the root up to this node.

Therefore, we can define a loop check as a function on the SLD-derivations instead of on the SLD-trees. However, for convenience we do not define it as a function from derivations to derivations, but as a set of derivations (depending on the program): the derivations that are pruned exactly at their last node. Such a set of SLD-derivations  $L(P)$  can be extended in a canonical way to a function  $f_{L(P)}$  from SLD-trees to SLD-trees by pruning in an SLD-tree the nodes in  $\{G \mid \text{the SLD-derivation from the root to } G \text{ is in } L(P)\}$ . In the remainder of this article, we shall usually make this conversion implicitly.

It is useful to note here that our definition of a loop check excludes more complicated pruning mechanisms for which the decision whether a node in a tree is pruned depends on the so far traversed segment of the considered tree. Such mechanisms are for example studied in [23] and [21].

We shall also study an even more restricted form of a loop check, called simple loop check, in which the set of pruned derivations is independent of the program  $P$ . In other words, a loop check is a function, having a program as input and a simple loop check as output. This leads us to the following definitions.

**Definition 2.1.** Let  $L$  be a set of SLD-derivations.  $\text{RemSub}(L) = \{D \in L \mid L \text{ does not contain a proper subderivation of } D\}$ .  $L$  is *subderivation free* if  $L = \text{RemSub}(L)$ .

In order to render the intuitive meaning of a loop check  $L$ : “every derivation  $D \in L$  is pruned *exactly* at its last node”, we need that  $L$  is subderivation free. Note that  $\text{RemSub}(\text{RemSub}(L)) = \text{RemSub}(L)$ .

In the following definition, by a *variant* of a derivation  $D$  we mean a derivation  $D'$  in which in every derivation step, atoms in the same positions are selected and the same programs clause are used.  $D'$  may differ from  $D$  in the renaming that is applied to these program clauses for reasons of standardizing apart and in the mgu

used. Thus any variant of an SLD-refutation is also an SLD-refutation and yields the same computed answer substitution up to a renaming.

**Definition 2.2.** A *simple loop check* is a computable set  $L$  of finite SLD-derivations such that  $L$  is closed under variants and subderivation free.

The first condition here ensures that the choice of variables in the input clauses in an SLD-derivation does not influence its pruning. This is a reasonable demand since we are not interested in the choice of the names of the variables in the derivations.

**Definition 2.3.** A *loop check* is a computable function  $L$  from programs to sets of SLD-derivations such that for every program  $P$ ,  $L(P)$  is a simple loop check.

Of course, we can treat a simple loop check  $L$  as a loop check, namely as the constant function  $\lambda P.L$ .

**Definition 2.4.** Let  $L$  be a loop check. An SLD-derivation  $D$  of  $P \cup \{G\}$  is *pruned* by  $L$  if  $L(P)$  contains a subderivation  $D'$  of  $D$ .

## 2.2. Example

**Example 2.5** (*Variant of Atom check*). (This example is based on Example 8 in [3], see also [10]). A first attempt to formulate the *Variant of Atom* (VA) check might be: “A derivation is pruned at the first goal that contains a variant  $A$  of an atom  $A'$  that occurred in an earlier goal”. Note that we have to allow here that  $A$  and  $A'$  are variants: if we required  $A = A'$  then we would violate the first condition in Definition 2.2.

The intuition behind this loop check is the following. We wish to prove  $A'$  by resolution. If we find out after some resolution steps that in order to prove  $A'$  we need to prove a variant  $A$  of  $A'$ , then there are two possibilities. One is that there is a proof for  $A$ . Then this proof could also be used as a proof for  $A'$ , by applying an appropriate renaming on it. So we do not need the proof of  $A'$  that goes via  $A$ . The other possibility is that there is no proof for  $A$ . In that case, the attempt to prove  $A'$  via  $A$  cannot be successful. So in both cases there is no reason to continue the attempt to prove  $A'$  via  $A$ .

The derivation step  $\leftarrow B, A \Rightarrow_{B \leftarrow} \leftarrow A$  shows that the first formulation of the VA check is not precise enough: it does not capture the intuition that the proof of  $A'$  goes via  $A$ . The atom  $A$  should be the result (after one or more derivation steps) of resolving  $A'$ , or a further instantiated version of  $A'$  (if  $A'$  is not immediately selected).

Therefore we define

VA = RemSub( $\{D \mid D = (G_0 \Rightarrow_{C_1, \theta_1} G_1 \Rightarrow \dots \Rightarrow G_{k-1} \Rightarrow_{C_k, \theta_k} G_k)$  such that for some  $i$  and  $j$ ,  $0 \leq i \leq j < k$ ,  $G_k$  contains an atom  $A$  that is

- a variant of an atom  $A'$  in  $G_i$  and
- the result of an attempt to resolve  $A' \theta_{i+1} \dots \theta_j$ , the further instantiated version of  $A'$ , that is selected in  $G_j$ }).

We now illustrate the use of this loop check. Let

- $P = \{A(0) \leftarrow. \quad (C1),$
- $B(1) \leftarrow. \quad (C2),$
- $A(x) \leftarrow A(y). \quad (C3),$
- $C \leftarrow A(x), B(x). \quad (C4)\}$ ,

let  $G = \leftarrow C$ .

That the informal justification of the loop check VA is incorrect, is shown by applying it to two SLD-trees of  $P \cup \{G\}$ , via the leftmost and rightmost selection rule respectively, which gives us Fig. 1. (In this figure and elsewhere, a failed node, i.e. a node without a successor in the SLD-tree, is marked by a box around it.)

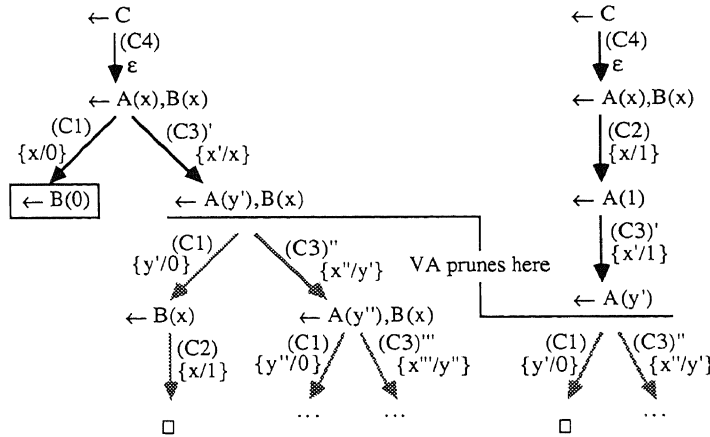

Fig. 1

A detailed analysis shows why the goal  $G_3 = \leftarrow A(y')$  in the rightmost tree is pruned by the VA check. Clearly, a variant of  $A(y')$  occurs in an earlier goal:  $A(x)$  in  $G_1$ . So we take  $i = 1$ . In  $G_1$ ,  $A(x)$  is not yet selected, so  $j > i$ . In fact  $j = 2$ , for in  $G_2$  the atom  $A(1)$ , which is a further instantiated version of  $A(x)$ , is selected. Indeed,  $A(y')$  is the result of resolving  $A(1)$ . Therefore the derivation is pruned at

$G_3$  by the VA check. (In this case,  $A(y')$  is the direct result of resolving  $A(1)$ , but in general there may be any number of derivation steps between  $G_j$  and  $G_k$ .)

Indeed, this loop check has not worked properly here: all successful derivations have been pruned. Clearly, this is an undesirable property for loop checks. On the other hand, all infinite derivations are pruned, as intended. In the next section, we shall give formal definitions of these and related properties of loop checks.

### 3. Some general considerations

In this section some basic properties of loop checks are introduced and some natural results concerning them are established.

#### 3.1. Soundness and completeness

The most important property is definitely that using a loop check does not result in a loss of success. Since we intend to use pruned trees instead of the original ones, we need at least that pruning a successful tree yields again a successful tree.

Even stronger, because we use here a Prolog-like interpreter augmented with a loop check as the *only* inference mechanism, we do not want to lose any individual solution. That is, if the original tree contains a successful branch (giving some computed answer), then we require that the pruned tree contains a successful branch giving a more general answer.

Finally, we would like to retain only shorter derivations and prune the longer ones that give the same result. This leads to the following definitions, where for a derivation  $D$ ,  $|D|$  stands for its length, i.e. the number of goals in it.

**Definition 3.1** (*Soundness*). (i) A loop check  $L$  is *weakly sound* if for every program  $P$  and goal  $G$ , and SLD-tree  $T$  of  $P \cup \{G\}$ : if  $T$  contains a successful branch, then  $f_{L(P)}(T)$  contains a successful branch.

(ii) A loop check  $L$  is *sound* if for every program  $P$  and goal  $G$ , and SLD-tree  $T$  of  $P \cup \{G\}$ : if  $T$  contains a successful branch with a computed answer substitution  $\sigma$ , then  $f_{L(P)}(T)$  contains a successful branch with a computed answer substitution  $\sigma'$  such that  $G\sigma' \leq G\sigma$ .

(iii) A loop check  $L$  is *shortening* if for every program  $P$  and goal  $G$ , and SLD-tree  $T$  of  $P \cup \{G\}$ : if  $T$  contains a successful branch  $D$  with a computed answer substitution  $\sigma$ , then either  $f_{L(P)}(T)$  contains  $D$  or  $f_{L(P)}(T)$  contains a successful branch  $D'$  with a computed answer substitution  $\sigma'$  such that  $G\sigma' \leq G\sigma$  and  $|D'| < |D|$ .

The following lemma is an immediate consequence of these definitions.

**Lemma 3.2.** *Let  $L$  be a loop check. (i) If  $L$  is shortening, then  $L$  is sound.*



(ii) *If  $L$  is sound, then  $L$  is weakly sound.*

The purpose of a loop check is to reduce the search space for top-down interpreters. We would like to end up with a finite search space. This is the case when every infinite derivation is pruned.

**Definition 3.3** (*Completeness*). A loop check  $L$  is *complete* if every infinite SLD-derivation is pruned by  $L$ .

We must point out that in these definitions we have overloaded the terms “soundness” and “completeness”. These terms do not refer here only to loop checks, but also to interpreters for logic programs (with or without a loop check). Such an interpreter is sound if any answer it gives is correct w.r.t. the intended model or the intended theory of the program. An interpreter is complete if it finds every correct answer within a finite time.

### 3.2. Interpreters and loop checks

When a top-down interpreter is augmented with a loop check, we obtain a new interpreter. The soundness and completeness of this new interpreter depends on the soundness and completeness of the old one, as well as on the soundness and completeness of the loop check. However, these relations are not trivial. For example, it is not true that adding a complete loop check to a complete interpreter yields again a complete interpreter.

These relationships are expressed in the following lemma’s. We refer here to two interpreters: one searching the SLD-tree depth-first left-to-right (as the Prolog interpreter does), and one searching breadth-first. Without a loop check, both interpreters are sound w.r.t. CWA. The breadth-first interpreter is also complete (but not complete w.r.t. CWA).

**Lemma 3.4.** *Let  $P$  be a program,  $A$  a ground atom and  $L$  a weakly sound loop check. Then for every SLD-tree  $T$  of  $P \cup \{\leftarrow A\}$ ,  $P \vdash_{\text{CWA}} \neg A$  iff  $f_{L(P)}(T)$  contains no successful branches.*

**Proof.** By the soundness and strong completeness of SLD-resolution (see [2, 16]).  $\square$

Thus an interpreter augmented with a weakly sound loop check remains sound w.r.t. CWA. Since  $f_{L(P)}(T)$  may be infinite, nothing can be said about completeness.

**Lemma 3.5.** *Let  $P$  be a program,  $A$  an atom and  $L$  a sound loop check. Then for every SLD-tree  $T$  of  $P \cup \{\leftarrow A\}$  and for every ground substitution  $\theta$ ,  $P \vdash A\theta$  iff  $f_{L(P)}(T)$  contains a successful branch with a computed answer substitution  $\tau$  such that  $A\tau \leq A\theta$ .*

**Proof.** We have by the strong completeness of SLD-resolution  $P \vdash A\theta \Leftrightarrow T$  contains a successful branch with a computed answer substitution  $\sigma$  such that  $A\sigma \leq A\theta$ .

( $\Rightarrow$ ):  $T$  contains this successful branch, and since  $L$  is sound,  $f_{L(P)}(T)$  contains a successful branch with a computed answer substitution  $\tau$  such that  $A\tau \leq A\sigma$ . Hence  $A\tau \leq A\theta$ .

( $\Leftarrow$ ):  $f_{L(P)}(T)$  contains a successful branch with a computed answer substitution  $A\tau \leq A\theta$ , so  $T$  contains this branch as well.  $\square$

Thus an interpreter augmented with a sound loop check remains sound. Moreover, a breadth-first interpreter remains complete.

**Corollary 3.6.** *Let  $P$  be a program,  $A$  a ground atom and  $L$  a weakly sound and complete loop check. Then for every SLD-tree  $T$  of  $P \cup \{\leftarrow A\}$ ,  $P \vdash_{CWA} \neg A$  iff  $f_{L(P)}(T)$  is finite and contains no successful branches.*

**Proof.** By Lemma 3.4 and the Completeness Definition 3.3.  $\square$

Thus an interpreter augmented with a weakly sound and complete loop check becomes complete w.r.t. CWA.

**Corollary 3.7.** *Let  $P$  be a program,  $A$  an atom and  $L$  a sound and complete loop check. Then for every SLD-tree  $T$  of  $P \cup \{\leftarrow A\}$  and for every ground substitution  $\theta$ ,  $P \vdash A\theta$  iff  $f_{L(P)}(T)$  is finite and contains a successful branch with a computed answer substitution  $\tau$  such that  $A\tau \leq A\theta$ .*

**Proof.** By Lemma 3.5 and the Completeness Definition 3.3.  $\square$

Thus a depth-first interpreter augmented with a sound and complete loop check becomes complete. This also means that a sound and complete loop check can be used to implement query processing as defined in the introduction. Indeed, given a program  $P$  and an atom  $A$  with an SLD-tree  $T$  of  $P \cup \{\leftarrow A\}$ , it suffices to traverse the finite tree  $f_{L(P)}(T)$  and collect all computed answer substitutions.

### 3.3. Comparing loop checks

After studying the relationships between loop checks and interpreters, we shall now analyze a relationship between loop checks themselves. In general, it can be quite difficult to compare loop checks. However, some of them can be compared in a natural way: if every loop that is detected by one loop check, is detected at the same derivation step or earlier by another loop check, then the latter one is *stronger* than the former.

**Definition 3.8.** Let  $L_1$  and  $L_2$  be loop checks.  $L_1$  is *stronger than*  $L_2$  if for every program  $P$  and goal  $G$ , every SLD-derivation  $D_2 \in L_2(P)$  of  $P \cup \{G\}$  contains a subderivation  $D_1$  such that  $D_1 \in L_1(P)$ .

In other words,  $L_1$  is stronger than  $L_2$  if every SLD-derivation that is pruned by  $L_2$  is also pruned by  $L_1$ . Note that the definition implies that every loop check is stronger than itself.

The following theorem will prove to be very useful. It will enable us to obtain soundness and completeness results for loop checks which are related by the “stronger than” relation, by proving soundness and completeness for only one of them.

**Theorem 3.9** (Relative strength). *Let  $L_1$  and  $L_2$  be loop checks, and let  $L_1$  be stronger than  $L_2$ .*

- (i) *If  $L_1$  is weakly sound, then  $L_2$  is weakly sound.*
- (ii) *If  $L_1$  is sound, then  $L_2$  is sound.*
- (iii) *If  $L_1$  is shortening, then  $L_2$  is shortening.*
- (iv) *If  $L_2$  is complete, then  $L_1$  is complete.*

**Proof.** (i)–(iii) If an SLD-tree  $T$  contains a successful branch, then  $f_{L_1(P)}(T)$  contains a successful branch that satisfies the conditions of Definition 3.1. Since  $L_1$  is stronger than  $L_2$ ,  $f_{L_1(P)}(T)$  is a subtree of  $f_{L_2(P)}(T)$ , so this branch is also contained in  $f_{L_2(P)}(T)$ .

(iv) Every infinite SLD-derivation is pruned by  $L_2$ , so it is also pruned by  $L_1$ .  $\square$

Now we have a clearer view of the situation. Very strong loop checks prune derivations in an “early stage”. If they prune too early, then they are unsound. Since this is undesirable, we must look for weaker loop checks. But a loop check should preferably be not too weak, for then it might fail to prune some infinite derivations (in other words, it might be incomplete). Of course, the “stronger than” relation is not linear. Moreover, loop checks exist that are neither sound nor complete.

### 3.4. Sound and complete loop checks

A question now arises: do there exist sound and complete loop checks? Obviously, there cannot be such a loop check for logic programs in general, as logic programming has the full power of recursion theory. (Remember that according to the definition, a loop check is computable.) So when studying completeness we shall rule out programs that compute over an infinite domain. We shall do so by restricting our attention to programs without function symbols, so called *function-free* programs. This restriction leads to a finite Herbrand Universe, but other solutions (typed functions, bounded term-size property [11]) are also possible here.

Note that our definitions so far referred to arbitrary programs and SLD-derivations. In the remainder of the paper, we shall consider certain classes of programs (like function-free programs) and SLD-derivations (like the derivations via the leftmost selection rule). The definitions we introduced can be extended in an obvious way so that we can use terminology like “complete w.r.t. the leftmost selection rule for function-free restricted programs”.

As stated above, we shall study completeness only for function-free programs. So our question can be reformulated as: is there a sound and complete loop check for function-free programs? Before answering this question for loop checks in general, we shall answer it for simple loop checks.

**Theorem 3.10.** *There is no weakly sound and complete simple loop check for function-free programs.*

**Proof.** Let  $L$  be a simple loop check that is complete for function free programs. Consider the infinite SLD-derivation  $D$  in Fig. 2, obtained by repeatedly using the clause  $A(x) \leftarrow A(y), S(y, x)$  (using the leftmost selection rule).

$$\begin{array}{c}
 \leftarrow A(x_0), B(x_0) \\
 \Downarrow \\
 \leftarrow A(x_1), S(x_1, x_0), B(x_0) \\
 \Downarrow \\
 \leftarrow A(x_2), S(x_2, x_1), S(x_1, x_0), B(x_0) \\
 \Downarrow \\
 \leftarrow A(x_3), S(x_3, x_2), S(x_2, x_1), S(x_1, x_0), B(x_0) \\
 \Downarrow \\
 \dots
 \end{array}$$

Fig. 2

Since  $L$  is a complete loop check, this derivation is pruned by  $L$  and since  $L$  is simple, the goal at which pruning takes place is independent of the program used for this derivation. Suppose that this derivation is pruned by  $L$  at the goal

$$\leftarrow A(x_n), S(x_n, x_{n-1}), \dots, S(x_1, x_0), B(x_0).$$

Now let

$$P = \{S(i, i+1) \leftarrow \cdot \mid 0 \leq i < n\} \cup \{A(0) \leftarrow \cdot, A(x) \leftarrow A(y), S(y, x), B(n) \leftarrow \cdot\}.$$

Extending the above derivation to an SLD-tree of  $P \cup \{G\}$  (still using the leftmost selection rule, see Fig. 3), we see that every goal of the derivation has two descendants, obtained by applying the clauses  $A(x) \leftarrow A(y), S(y, x)$  and  $A(0) \leftarrow$  respectively. The derivation of Fig. 2 shows the effect of repeatedly applying  $A(x) \leftarrow A(y), S(y, x)$ . After applying  $A(0) \leftarrow$  at some goal, a derivation becomes deterministic: if there are initially  $m$   $S$ -atoms, then these atoms are resolved from left to right by the clauses  $S(0, 1) \leftarrow \cdot, \dots, S(m-1, m) \leftarrow \cdot$ .

Finally, the goal  $\leftarrow B(m)$  is left. Since of all goals of the form  $\leftarrow B(i)$  ( $i \geq 0$ ) only the goal  $\leftarrow B(n)$  can be refuted, exactly  $n$   $S$ -atoms are needed. Therefore the only successful branch of this SLD-tree of  $P \cup \{G\}$  goes via the goal  $\leftarrow A(x_n), S(x_n, x_{n-1}), \dots, S(x_1, x_0), B(x_0)$ . As exactly this goal is pruned by  $L$ ,  $L$  has pruned the only successful branch of this SLD-tree. Hence  $L$  is not weakly sound.  $\square$

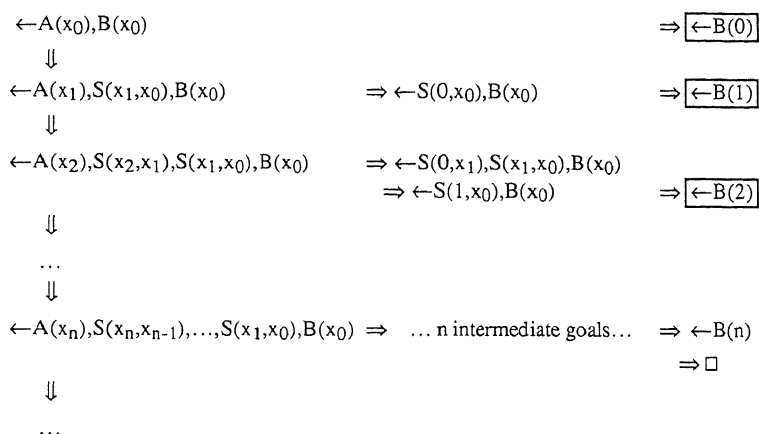

Fig. 3

However, taking the program into account gives us an opportunity to define for function-free programs a shortening (so a fortiori sound) loop check which is complete. Moreover, this loop check is stronger than *every* other shortening loop check. Strange as it may seem, this one is also impractical. It is like solving a puzzle by trial and error. One can save effort if one can avoid the trials that lead to an error. Assuming that the puzzle is solvable (as our “puzzle”, finding the correct answers to a given goal, is), it is possible to find out *exactly* which trials to avoid. How this can be done is formalized in the proof of Theorem 3.13 (1). However, solving the puzzle is the first step of the method described, so it can only be of theoretical importance.

For convenience, we shall write  $S(P, G, \sigma)$  for the set of successful SLD-derivations of  $P \cup \{G\}$  with a computed answer substitution  $\tau$  such that  $G\tau \leq G\sigma$ . We say that a derivation  $D$  is a *minimal length derivation* in  $S(P, G, \sigma)$  if  $D \in S(P, G, \sigma)$  and  $|D| = \min\{|D'| \mid D' \in S(P, G, \sigma)\}$ .

**Definition 3.11** (STRONG check). For a function-free program  $P$ ,  $\text{STRONG}(P) = \text{RemSub}(\{D = G \Rightarrow \dots \mid \text{for no } \sigma, D \text{ is an initial segment of a minimal length derivation in } S(P, G, \sigma)\})$ .

Note that an SLD-tree pruned by STRONG consists not only of the minimal length refutation(s) of  $P \cup \{G\}$  for any computed answer substitution  $\sigma$ , but also of the derivations that follow the path of such a derivation but “make a wrong decision”, that is a step deviating from such a refutation. After such a step, the derivation is immediately pruned by STRONG. This effect is a consequence of the fact that pruning a node in a tree implies removing *all* descendants, so we cannot remove the descendants caused by a “wrong step” while retaining the others. The following example shows the effect of pruning an SLD-tree by STRONG.

**Example 3.12.** Let

- $$\begin{aligned}
 P = \{ & A(1) \leftarrow. && (C1), \\
 & A(y) \leftarrow B(y, z), A(z). && (C2), \\
 & B(w, 0) \leftarrow. && (C3), \\
 & B(0, 1) \leftarrow. && (C4)\},
 \end{aligned}$$

and let  $G = \leftarrow A(x)$ .

Consider an SLD-tree of  $P \cup \{G\}$  displayed in Fig. 4. In  $S(P, G, \{x/1\})$  a minimal length derivation has 2 goals, in  $S(P, G, \{x/0\})$  a minimal length derivation has 4 goals and in  $S(P, G, \varepsilon)$  a minimal length derivation has 6 goals. These derivations

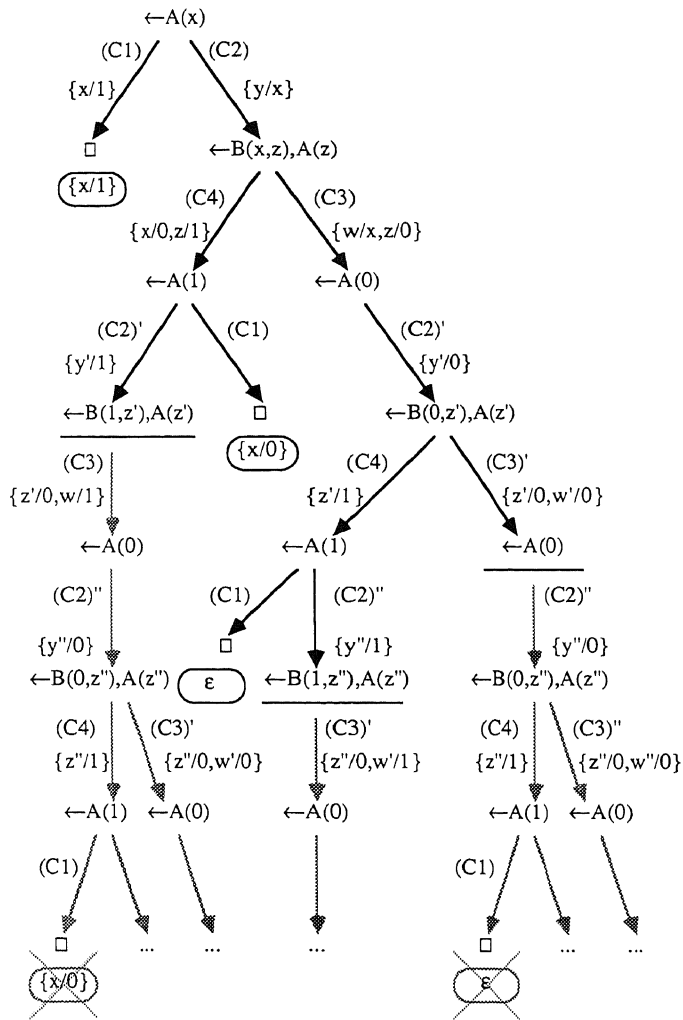

Fig. 4

are retained by STRONG in the considered SLD-tree, the others are pruned (at the horizontal lines in the figure). Among these are successful ones, but not minimal length successful ones. (The tree in Fig. 4 is extended beyond the sixth level to show this effect.)

**Theorem 3.13.** *For function-free programs,*

- (i) STRONG is a shortening loop check;
- (ii) STRONG is stronger than any shortening loop check;
- (iii) STRONG is complete.

**Proof.** (i) a) STRONG is a loop check. The nontrivial point here is to prove that for every function-free program  $P$ ,  $\text{STRONG}(P)$  is computable. Can we, given a derivation  $D = G \Rightarrow \dots$ , decide whether or not  $D$  is pruned by STRONG and if so, at which node? Indeed we can, using the following procedure.

(1) Compute the set of correct answers for  $P \cup \{G\}$ , modulo renamings (e.g. bottom up). Since  $P$  has no function symbols, this set is finite. Construct (breadth first) an initial segment of an SLD-tree of  $P \cup \{G\}$  that contains (an initial part of)  $D$  and for each correct answer a successful branch with a more general computed answer. Such a segment exists by the strong completeness of SLD-resolution. It has been shown in [13] that a length preserving bijection exists between the successful branches of two different SLD-trees for  $P \cup \{G\}$ . Therefore in every SLD-tree of  $P \cup \{G\}$ , for every correct answer substitution  $\sigma$  there exists a derivation  $D' \in S(P, G, \sigma)$  with  $|D'| = \min\{|D''| \mid D'' \in S(P, G, \sigma)\}$ .

(2) For each computed answer substitution, mark the nodes of the minimal length successful branches with this computed answer substitution.

(3) Prune  $D$  at the first node in the tree that is not marked. If such a node does not exist, then  $D$  is a subderivation of a minimal length successful branch.

(i) b) STRONG is shortening. If a successful derivation  $D$  of  $P \cup \{G\}$  with computed answer substitution  $\sigma$  is pruned by STRONG, then it is not a minimal length derivation in  $S(P, G, \sigma)$ . By construction, there exists a minimal length derivation  $D' \in S(P, G, \sigma)$  in the SLD-tree.  $D'$  is shorter than  $D$  and not pruned by STRONG.

(ii) STRONG is stronger than any shortening loop check. Let  $L$  be a loop check and let  $D$  be a derivation of  $P \cup \{G\}$  that is pruned by  $L$ . If  $D$  is a subderivation of a minimal length successful derivation  $D'$ , then  $L$  is not shortening. Otherwise,  $D$  is pruned by STRONG.

(iii) STRONG is complete. If  $D$  is an infinite SLD-derivation, then only an initial segment of  $D$  is contained in the constructed (finite) part of the SLD-tree. Since the last goal of  $D$  that is in the tree is not successful, it is not marked in the procedure for computing STRONG. So  $D$  contains a “wrong step” there or earlier. Hence  $D$  is pruned by STRONG.  $\square$

So far, we have not been very successful in defining useful sound and complete loop checks. In the next sections, we shall restrict our attention to simple loop

checks. They will be shortening, but as shown above, they cannot be complete (not even for function-free programs). Nevertheless, for each of these loop checks we shall introduce one or more natural classes of programs for which they are complete.

## 4. Equality checks

### 4.1. Overview

In this section, we introduce some simple loop checks. For each of them, there exist two versions: the first one is weakly sound, the second one shortening. The second shortening version is obtained by adding an additional condition to the criterion that describes the derivations pruned by the first one. By this construction, the first version is always stronger than the corresponding second version.

Starting with the Variant of Atom check, we can make three independent modifications of it.

(1) Adding this additional condition to the loop check's criterion. This condition mainly deals with the computed answer substitution 'generated so far' and is more or less equivalent to applying the criterion to *resultants* instead of goals in SLD-derivations. When considering a derivation  $G_0 \Rightarrow_{C_1, \theta_1} G_1 \Rightarrow \dots$ , to every goal  $G_i = \leftarrow S_i$  there corresponds the resultant  $R_i = S_0 \theta_1 \dots \theta_i \leftarrow S_i$ . Resultants were introduced in [17].

(2) Replace *variant* by *instance*. This yields the *Instance of Atom (IA)* check. This check is still unsound: it is even stronger than the VA check. Besnard [3] has introduced a weakly sound version of this loop check. This check and related ones (derived from VA; shortening versions) are discussed in Section 6.

(3) Replace *atom* by *goal*. This yields the *Equals Variant of Goal (EVG)* check. Informally, this loop check prunes a derivation as soon as a *goal* occurs that is a variant of an earlier goal. Replacing "variant" by "instance" again yields the *Equals Instance of Goal (EIG)* check. The shortening versions are called *Equals Variant of Resultant (EVR)* and *Equals Instance of Resultant (EIR)*.

Taking goals instead of atoms as a basis for a loop check yields two independent choices again.

(3a) Whereas equality between atoms is unambiguous, equality between goals is much less clear. In SLD-derivations, we regard goals as lists, so both the number and the order of occurrences of atoms is important. However, we may also regard them as multisets, where the order of the occurrences is unimportant. We might even consider regarding them as sets, but that proves to be impractical: the difference between the derivation steps  $\leftarrow A, A \Rightarrow \leftarrow A$  and  $\leftarrow A \Rightarrow \leftarrow A$  is then no longer visible. Regarding goals as sets in our loop checks would require regarding goals as sets in SLD-derivations, which would result in too many undesirable effects.

So we shall consider *two* EVG checks:  $EVG_L$  (for list) and  $EVG_M$  (for multiset). The same holds for EIG, EVR and EIR. We shall refer to these eight loop checks as the *equality* checks. They are discussed in the remainder of this section.



(3b) Finally, we may replace “ $G_2$  is a variant/instance of  $G_1$ ” by “ $G_2$  is subsumed by a variant/instance of  $G_1$ ”. We define “ $G_1$  subsumes  $G_2$ ” as “ $G_1 \subseteq G_2$ ”. Thus we can make a distinction between “subsumed by a variant” and “subsumed by an instance”. Usually in literature, “subsumed by a variant” is not considered, “subsumed by an instance” is simply called “subsumed” (see, e.g., [6]). Subsumption can also be defined for resultants.

This yields the *subsumption* check. Since this modification is again independent of the others, there are also eight subsumption checks. These checks are discussed in Section 5.

#### 4.2. Formal definitions

We now study the equality checks in more detail. At first we give a formal definition of the weakly sound versions. Then we introduce an additional condition that makes these checks shortening. Finally, we identify a natural class of programs for which the equality checks are complete.

In fact, we should give a definition for each equality check. This would yield eight almost identical definitions. Therefore we compress them into two definitions, trusting that the reader is willing to understand our notation. The equality relation between goals regarded as lists is denoted by  $=_L$ ; similarly  $=_M$  for multisets. We begin with the weakly sound versions.

**Definition 4.1** (*Equality checks for goals*). For  $Type \in \{L, M\}$ , the *Equals Variant/Instance of Goal<sub>Type</sub>* check is the set of SLD-derivations

$$\text{EVG/EIG}_{Type} = \text{RemSub}(\{D \mid D = (G_0 \Rightarrow_{C_1, \theta_1} G_1 \Rightarrow \dots \Rightarrow G_{k-1} \Rightarrow_{C_k, \theta_k} G_k) \\ \text{such that for some } i, 0 \leq i < k, \text{ there is a} \\ \text{renaming/substitution } \tau \text{ such that} \\ G_k =_{Type} G_i \tau\}).$$

For example,  $\text{EIG}_M = \text{RemSub}(\{D \mid D = (G_0 \Rightarrow_{C_1, \theta_1} G_1 \Rightarrow \dots \Rightarrow G_{k-1} \Rightarrow_{C_k, \theta_k} G_k) \\ \text{such that for some } i, 0 \leq i < k, \text{ there is a substitution } \tau \text{ such that } G_k =_M G_i \tau\}).$

The informal justification for these loop checks is similar to the one given for the VA check. Suppose that we want to refute a goal  $G$ . If we find that in order to refute  $G$  we need to refute a variant or instance of  $G$ , say  $G\tau$ , then two cases arise. If there is no solution for  $G\tau$ , then pruning  $G\tau$  is clearly safe. On the other hand, if there is a solution for  $G\tau$ , then the derivation giving this solution might be used (possibly in a more general form) directly from  $G$ .

We shall prove later in this section that these loop checks are weakly sound. However, they are not sound. To see this, suppose that we find for  $G\tau$  a successful derivation  $D$  with a computed answer substitution  $\sigma$ . Then using  $D$  directly from  $G$  gives a computed answer substitution  $\tau\sigma$  (maybe a more general substitution, but not necessarily). Therefore success is not lost.

However, the derivation  $G = G_i \Rightarrow_{C_{i+1}, \theta_{i+1}} \dots \Rightarrow_{C_k, \theta_k} G_k = G\tau$ , followed by  $D$ , yields a possibly different computed answer substitution:  $\theta_{i+1} \dots \theta_k \sigma$ , thus possibly

affecting soundness. (In Example 4.3, we show a specific program and goal for which this difference arises.) Of course, we are only interested in the effect of this difference on the variables of the initial goal  $G_0$ . When  $G_i$  is reached, these variables are renamed by  $\theta_1 \dots \theta_i$ . So  $\tau$  and  $\theta_{i+1} \dots \theta_k$  should coincide on the variables of  $G_0\theta_1 \dots \theta_i$ .

Hence we can make these loop checks sound, and even shortening, by adding the condition  $G_0\theta_1 \dots \theta_k = G_0\theta_1 \dots \theta_i\tau$ . (Note that in this equality it is irrelevant whether goals are lists or multisets.) It will appear that this condition works not only for EVG and EIG, but for all other loop checks studied in Sections 5 and 6, as well.

Finally, note that adding this condition is equivalent to the replacement of the condition  $G_k =_{Type} G_i\tau$  by the condition  $R_k =_{Type} R_i\tau$ , where  $R_k$  and  $R_i$  are the resultants corresponding to the goals  $G_k$  and  $G_i$ .

**Definition 4.2** (*Equality checks for resultants*). For  $Type \in \{L, M\}$ , the *Equals Variant/ Instance of Resultant* $_{Type}$  check is the set of SLD-derivations

$$\begin{aligned} \text{EVR/EIR}_{Type} = \text{RemSub}(\{D \mid D = (G_0 \Rightarrow_{C_1, \theta_1} G_1 \Rightarrow \dots \Rightarrow G_{k-1} \Rightarrow_{C_k, \theta_k} G_k) \\ \text{such that for some } i, 0 \leq i < k, \text{ there is a} \\ \text{renaming/substitution } \tau \text{ such that} \\ G_k =_{Type} G_i\tau \text{ and } G_0\theta_1 \dots \theta_k = \\ G_0\theta_1 \dots \theta_i\tau\}). \end{aligned}$$

For example,  $\text{EVR}_L = \text{RemSub}(\{D \mid D = (G_0 \Rightarrow_{C_1, \theta_1} G_1 \Rightarrow \dots \Rightarrow G_{k-1} \Rightarrow_{C_k, \theta_k} G_k) \\ \text{such that for some } i, 0 \leq i < k, \text{ there is a renaming } \tau \text{ such that } G_k =_L G_i\tau \text{ and} \\ G_0\theta_1 \dots \theta_k = G_0\theta_1 \dots \theta_i\tau\}).$

The following example shows the difference between the goal-based and resultant-based equality checks. It is so chosen that the other variations (variants or instances, goals regarded as lists or as multisets) do not play a role.

**Example 4.3.** Let

$$\begin{aligned} P = \{p(a) \leftarrow. \quad (C1), \\ p(y) \leftarrow p(z). \quad (C2)\}, \end{aligned}$$

let  $G = \leftarrow p(x)$ .

Without the condition  $G_0\theta_1 \dots \theta_k = G_0\theta_1 \dots \theta_i\tau$  we would only obtain the computed answer substitution  $\{x/a\}$ , whereas we should also obtain the empty substitution. This shows that the EVG and EIG loop checks are not sound.

In the leftmost tree in Fig. 5  $\leftarrow p(z)$  is a variant of  $\leftarrow p(x)$ , so the derivation is pruned by EVG at that goal. However, the corresponding resultant  $p(x) \leftarrow p(z)$  is clearly not a variant of  $p(x) \leftarrow p(x)$ , therefore the derivation is not yet pruned by EVR. After another application of (C2), the resultant  $p(x) \leftarrow p(z')$  occurs, which is a variant of  $p(x) \leftarrow p(z)$ . At that point the derivation is pruned by EVR.

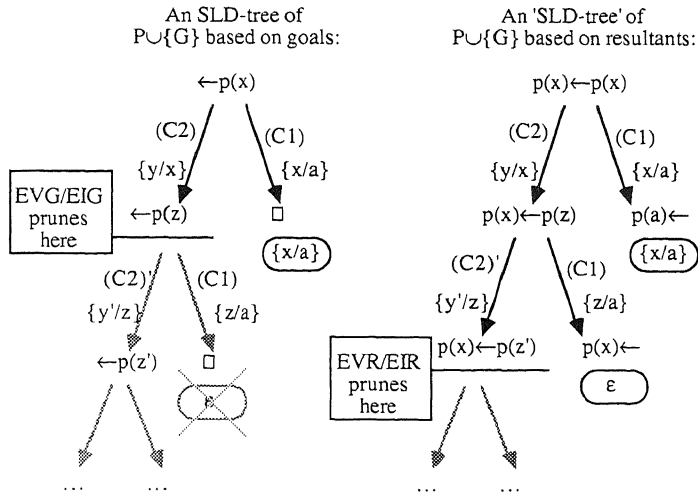

Fig. 5

The rightmost tree in Fig. 5 shows an ‘‘SLD-tree’’ in which the goals are replaced by the corresponding resultants. Note that a successful branch in a resultant-based SLD-tree does not end by the empty goal  $\square$ , but by the instance of the initial goal that was ‘proved’ by this branch.

**Lemma 4.4.** *All equality checks are simple loop checks.*

Figure 6 shows the ‘‘stronger than’’ relationships between the equality checks (and the VA and IA checks) and summarizes their properties. In this figure, an arrow  $L_1 \rightarrow L_2$  means that  $L_2$  is stronger than  $L_1$ . Proving these ‘‘stronger than’’ relations is straightforward.

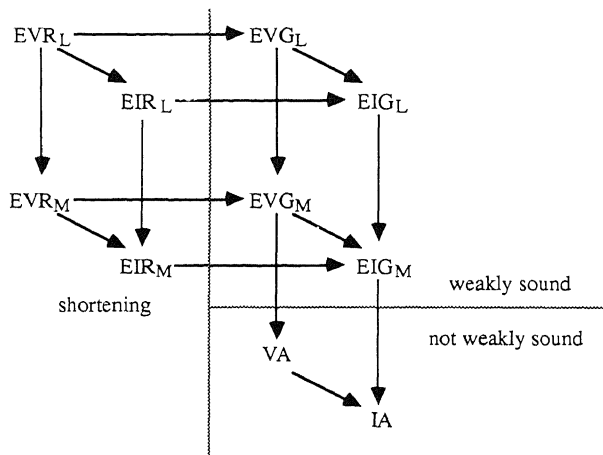

Fig. 6

### 4.3. Soundness

We now prove that the equality checks based on resultants are shortening and that the equality checks based on goals are weakly sound. According to the Relative strength Theorem 3.9 it is sufficient to focus on the strongest checks in both classes: the  $EIR_M$  and the  $EIG_M$  checks. The proof consists of two stages. The first stage, established in the following lemma, does not depend on the loop checking criterion and can therefore also be used to prove the soundness of the simple loop checks presented in the following sections.

**Lemma 4.5** (Shortening condition). *Let  $L$  be a loop check. If, for every program  $P$ , goal  $G_0$  and SLD-derivation*

$$D = (G_0 \Rightarrow_{c_1, \theta_1} G_1 \Rightarrow \cdots \Rightarrow G_{k-1} \Rightarrow_{c_k, \theta_k} G_k \Rightarrow \cdots \Rightarrow_{c_m, \theta_m} \square)$$

of  $P \cup \{G_0\}$  ( $0 < k \leq m$ ),

$$[G_k \text{ is pruned by } L]$$

*implies [for some goal  $G_i$  ( $0 \leq i < k$ ) in  $D$  there exists an SLD-derivation*

$$G_i \Rightarrow_{\sigma_1} \cdots \Rightarrow_{\sigma_n} \square \text{ of } P \cup \{G_i\} \text{ such that } n < m - i],$$

*then  $L$  is weakly sound.*

*Moreover, if also  $G_0 \theta_1 \dots \theta_i \sigma_1 \dots \sigma_n \leq G_0 \theta_1 \dots \theta_k \theta_{k+1} \dots \theta_m$  is implied, then  $L$  is shortening.*

**Proof.** First we focus on the weakly sound case. Let  $P$  be a program,  $G_0$  a goal and  $T$  an SLD-tree of  $P \cup \{G_0\}$ . Suppose  $T$  contains a successful branch

$$D = (G_0 \Rightarrow_{c_1, \theta_1} G_1 \Rightarrow \cdots \Rightarrow G_{i-1} \Rightarrow_{c_i, \theta_i} G_i \Rightarrow \cdots \Rightarrow G_{k-1} \\ \Rightarrow_{c_k, \theta_k} G_k \Rightarrow \cdots \Rightarrow_{c_m, \theta_m} \square)$$

and suppose that  $D$  is pruned at  $G_k$ . We use here induction on  $m$ , i.e. we assume that for every successful branch  $B$  in  $T$  shorter than  $D$ ,  $f_L(T)$  contains either  $B$  or a successful branch shorter than  $B$ .

We prove that  $f_L(T)$  contains a successful branch  $D'$  that is shorter than  $D$ . By assumption and SLD-derivation  $D_1 = (G_i \Rightarrow_{\sigma_1} \cdots \Rightarrow_{\sigma_n} \square)$  of  $P \cup \{G_i\}$  exists. Adding (a properly renamed version of)  $D_1$  to the initial part of  $D$  gives the derivation

$$D_2 = (G_0 \Rightarrow_{c_1, \theta_1} G_1 \Rightarrow \cdots \Rightarrow G_{i-1} \Rightarrow_{c_i, \theta_i} G_i \Rightarrow_{\tau_1} \cdots \Rightarrow_{\tau_n} \square).$$

By the independence of the selection rule,  $T$  contains a branch  $D_3$  such that  $|D_3| = |D_2|$  and the computed answers of  $D_3$  and  $D_2$  are variants [13]. Since  $D_3$  is shorter than  $D$  ( $|D_3| = i + n + 1 < i + (m - i) + 1 = m + 1 = |D|$ ), by the induction hypothesis  $f_L(T)$  contains either  $D' = D_3$  or a successful branch  $D'$  shorter than  $D_3$ , which proves the claim.

For the shortening case, it remains to prove that  $G_0\sigma' \leq G_0\theta_1 \dots \theta_m$ , where  $\sigma'$  is the computed answer substitution of  $D'$ . First we strengthen the induction hypothesis: for every successful branch  $B$  in  $T$  shorter than  $D$  giving a computed answer substitution  $\sigma$ ,  $f_L(T)$  contains either  $B$  or a successful branch shorter than  $B$ , giving a computed answer substitution  $\sigma'$  such that  $G_0\sigma' \leq G_0\sigma$ .

Then either since  $D' = D_3$  or by the new induction hypothesis, and since the computed answers of  $D_3$  and  $D_2$  are variants,

$$G_0\sigma' \leq G_0\theta_1 \dots \theta_i\tau_1 \dots \tau_n \leq G_0\theta_1 \dots \theta_i\sigma_1 \dots \sigma_n \leq G_0\theta_1 \dots \theta_m. \quad \square$$

We now use this lemma to prove the desired result.

**Theorem 4.6.** (i) *The loop check  $\text{EIR}_M$  is shortening.*

(ii) *The loop check  $\text{EIG}_M$  is weakly sound.*

**Proof.** Let  $P$  be a program,  $G_0$  a goal and

$$\begin{aligned} D = (G_0 \Rightarrow_{C_1, \theta_1} G_1 \Rightarrow \dots \Rightarrow_{C_{i-1}, \theta_{i-1}} G_i \Rightarrow \dots \Rightarrow_{C_k, \theta_k} G_k \Rightarrow \dots \Rightarrow_{C_m, \theta_m} \square) \\ \Rightarrow_{C_k, \theta_k} G_k \Rightarrow \dots \Rightarrow_{C_m, \theta_m} \square \end{aligned}$$

an SLD-derivation of  $P \cup \{G_0\}$  (where  $0 \leq i < k \leq m$ ).

(i) Assume that for some substitution  $\tau$ :  $G_k =_M G_i\tau$  and  $G_0\theta_1 \dots \theta_k = G_0\theta_1 \dots \theta_i\tau$ . So the SLD-derivation  $G_i\tau \Rightarrow_{C_{k+1}, \theta_{k+1}} \dots \Rightarrow_{C_m, \theta_m} \square$  exists (the order of the atoms in  $G_i\tau$  may differ from the order in  $G_k$ , so a different selection rule may be necessary). By the Lifting Lemma of [16] a derivation  $G_i \Rightarrow_{\sigma_1} \dots \Rightarrow_{\sigma_n} \square$  of  $P \cup \{G_i\}$  exists, with  $\sigma_1 \dots \sigma_n \leq \tau\theta_{k+1} \dots \theta_m$  ( $n = m - k < m - i$ ). Now

$$G_0\theta_1 \dots \theta_i\sigma_1 \dots \sigma_n \leq G_0\theta_1 \dots \theta_i\tau\theta_{k+1} \dots \theta_m = G_0\theta_1 \dots \theta_k\theta_{k+1} \dots \theta_m,$$

hence the full condition of Lemma 4.5 is satisfied, so  $\text{EIR}_M$  is shortening.

(ii) The additional condition  $G_0\theta_1 \dots \theta_k = G_0\theta_1 \dots \theta_i\tau$  was only used to prove the additional shortening condition of Lemma 4.5.  $\square$

**Corollary 4.7** (Equality soundness). (i) *All equality checks based on resultants are shortening. A fortiori they are sound*

(ii) *All equality checks based on goals are weakly sound.*

**Proof.** By Theorem 4.6 and the Relative strength Theorem 3.9.  $\square$

#### 4.4. Completeness

For completeness issues, it is sufficient to consider the weakest of the equality checks: the  $\text{EVR}_L$  check. We know that  $\text{EVR}_L$  is not complete (Theorem 3.10 presents a counterexample that holds for every simple loop check). However, for the  $\text{EVR}_L$  check this counterexample can be simplified. The program in Theorem 3.10 consists

of a collection of ground facts and one recursive clause. Clearly, this clause is the “core” of the counterexample. It appears that for  $\text{EVR}_L$ , we need only this clause for a demonstration of its incompleteness. Moreover, we need only the propositional structure of the clause, i.e. we may remove the arguments.

**Example 4.8.** Let  $P = \{A \leftarrow A, S\}$ . Then for “the” SLD-tree  $T$  of  $P \cup \{\leftarrow A\}$  via the leftmost selection rule,  $f_{\text{EVR}_L}(T)$  is infinite. Indeed, every descendant of the initial goal has one occurrence of  $S$  more than its parent goal, so it cannot be a variant of any of its ancestors.

Obviously, the problem is that the atom  $A$  in the goal is allowed to generate infinitely many  $S$ -atoms, which are never selected, thereby making the goal wider and wider. We now introduce a class of programs for which this phenomenon cannot occur and we prove that  $\text{EVR}_L$  is complete for these programs. The necessary restriction is obtained by allowing at most one recursive call per clause and allowing such a call only after all other atoms in the body of the clause have been completely resolved. In order to avoid unnecessary complications, we shall place the atom that causes the recursive call (if present) at the right end of the body of the clause, and consider only derivations via the leftmost selection rule. For a formal definition, we use the notion of the *dependency graph*  $D_P$  of a program  $P$ .

**Definition 4.9.** The *dependency graph*  $D_P$  of a program  $P$  is a directed graph whose nodes are the predicate symbols appearing in  $P$  and  $(p, q) \in D_P$  iff there is a clause in  $P$  using  $p$  in its head and  $q$  in its body.

$D_P^*$  is the reflexive, transitive closure of  $D_P$ . When  $(p, q) \in D_P^*$ , we say that  $p$  *depends on*  $q$ . For a predicate symbol  $p$ , the *class of*  $p$  is the set of predicate symbols  $p$  “mutually depends” on:  $cl_P(p) = \{q \mid (p, q) \in D_P^* \text{ and } (q, p) \in D_P^*\}$ .

**Definition 4.10 (Restricted program).** Given an atom  $A$ , let  $rel(A)$  denote its predicate symbol. Let  $P$  be a program. A clause  $A_0 \leftarrow A_1, \dots, A_n$  ( $n \geq 0$ ) is called *restricted w.r.t.  $P$*  if for  $i = 1, \dots, n-1$ ,  $rel(A_i)$  does not depend on  $rel(A_0)$  in  $P$ . The atoms  $A_1, \dots, A_{n-1}$  are called the *nonrecursive* atoms of the clause  $A_0 \leftarrow A_1, \dots, A_n$ . A program  $P$  is called *restricted* if every clause in  $P$  is restricted w.r.t.  $P$ .

Note that this definition allows at most one recursive call per clause. Thus (disregarding the order of atoms in the bodies) restricted programs include so called linear programs, which contain only one recursive clause and in this clause only a single recursive call occurs. The “transitive closure” program given in the introduction is restricted. Note also that programs of which all clauses have a body with at most one atom are restricted. See also [22], where essentially the same class of programs is defined and investigated, although a more rigid format is used.

We now prove that  $\text{EVR}_L$  is complete w.r.t. the leftmost selection rule for restricted programs. First we demonstrate an interesting feature of restricted programs, namely

that in each SLD-derivation via the leftmost selection rule, goals have a number of atoms which is bounded by a value depending only on the program and the initial goal. Then we shall show that this implies that modulo the “being a variant of” relation, the number of possible goals in such an SLD-derivation is finite.

In the rest of this section,  $P$  is a function-free restricted program and  $G$  is a goal in  $L_P$ . With the *length* of  $G$ ,  $|G|$ , we mean the number of atoms in  $G$ . The maximum length of the goals in a derivation of  $P \cup \{G\}$  can be computed by means of the following *weight*-function, which is defined on goals and predicate symbols (by mutual induction).

**Definition 4.11.** Let  $P$  be a restricted program. Then the function *weight* is defined as follows:

(i) for a goal  $G = \leftarrow A_1, \dots, A_n$  ( $n \geq 1$ ) in  $L_P$ ,

$$\text{weight}(G) = \max\{\text{weight}(\text{rel}(A_i)) + n - i \mid i = 1, \dots, n\};$$

(ii) for a predicate symbol  $p$  of  $P$ ,

$$\begin{aligned} \text{weight}(p) = \max\{ & \{\text{weight}(\leftarrow A_1, \dots, A_n) \mid A \leftarrow A_1, \dots, A_n \in P, n > 0, \\ & \text{rel}(A) \in \text{cl}_P(p), \text{rel}(A_n) \notin \text{cl}_P(p)\} \\ & \cup \{1 + \text{weight}(\leftarrow A_1, \dots, A_{n-1}) \mid A \leftarrow A_1, \dots, A_n \in P, n > 1, \\ & \text{rel}(A) \in \text{cl}_P(p), \text{rel}(A_n) \in \text{cl}_P(p)\} \\ & \cup \{1\}\}. \end{aligned}$$

Note that in the definition of  $\text{weight}(p)$ , clauses of the form  $A \leftarrow B$ , with  $\text{cl}(\text{rel}(A)) = \text{cl}(\text{rel}(B))$  are not considered, they do not affect the length of goals appearing in a derivation. Moreover, if the predicate symbols  $p$  and  $q$  are mutually dependent, then  $\text{weight}(p) = \text{weight}(q)$ .

The fact that  $P$  is restricted ensures that the weight-function is well-defined: if  $\text{weight}(p)$  is defined in terms of  $\text{weight}(q)$ , then  $(q, p) \notin D_p^*$ , hence  $\text{weight}(q)$  is not defined in terms of  $\text{weight}(p)$ . Intuitively, the weight of a goal  $G$  majorizes the length of all goals which appear in an SLD-derivation of  $P \cup \{G\}$  using leftmost selection rule. More precisely, we have the following lemma's.

**Lemma 4.12.**  $|G| \leq \text{weight}(G)$ .

**Proof.** Let  $G = \leftarrow A_1, \dots, A_n$  ( $n \geq 1$ ). Then

$$\text{weight}(G) \geq \text{weight}(\text{rel}(A_1)) + n - 1 \geq n = |G| \quad \square$$

**Lemma 4.13.** Let  $G \Rightarrow_C H$  be a derivation step w.r.t.  $P$  where the leftmost atom of  $G$  is selected. Then  $\text{weight}(G) \geq \text{weight}(H)$ .

**Proof.** Since the weight of a goal depends only on the predicates appearing in it, and not on the arguments of these predicates, we prove this fact for the case of programs written in propositional logic.

Let  $G = \leftarrow A_1, \dots, A_n$ ; then  $\text{weight}(G) = \max\{\text{weight}(A_i) + n - i \mid i = 1, \dots, n\}$ , and let  $C = A_1 \leftarrow B_1, \dots, B_m$ . Then the goal  $H = \leftarrow B_1, \dots, B_m, A_2, \dots, A_n$  and therefore

$$\begin{aligned} \text{weight}(H) &= \max(\{\text{weight}(B_i) + m + n - 1 - i \mid i = 1, \dots, m\} \\ &\quad \cup \{\text{weight}(A_{i-m+1}) + m + n - 1 - i \mid i = m+1, \dots, m+n-1\}) \\ &= \max(\{\text{weight}(B_i) + m + n - 1 - i \mid i = 1, \dots, m\} \\ &\quad \cup \{\text{weight}(A_i) + n - i \mid i = 2, \dots, n\}). \end{aligned}$$

Two cases arise.

(i)  $\text{weight}(H) = \max\{\text{weight}(A_i) + n - i \mid i = 2, \dots, n\}$ . Then clearly  $\text{weight}(H) \leq \text{weight}(G)$ .

(ii)  $\text{weight}(H) = \max\{\text{weight}(B_i) + m + n - 1 - i \mid i = 1, \dots, m\}$  (hence  $m > 0$ ). We show that in this case  $\text{weight}(H) \leq \text{weight}(A_1) + n - 1$  (which is  $\leq \text{weight}(G)$ ). Subtracting  $n - 1$ , it suffices to show that  $\max\{\text{weight}(B_i) + m - i \mid i = 1, \dots, m\} \leq \text{weight}(A_1)$ . Again two cases arise.

(iia)  $(B_m, A_1) \notin D_p^*$ . Then because of the existence of  $C$ ,

$$\begin{aligned} \text{weight}(A_1) &\geq \text{weight}(\leftarrow B_1, \dots, B_m) \\ &= \max\{\text{weight}(B_i) + m - i \mid i = 1, \dots, m\}. \end{aligned}$$

(iib)  $(B_m, A_1) \in D_p^*$ . Then

$$\begin{aligned} \text{weight}(A_1) &\geq 1 + \text{weight}(\leftarrow B_1, \dots, B_{m-1}) \\ &= 1 + \max\{\text{weight}(B_i) + m - 1 - i \mid i = 1, \dots, m-1\} \\ &= \max\{\text{weight}(B_i) + m - i \mid i = 1, \dots, m-1\}. \end{aligned}$$

Also  $\text{weight}(B_m) + m - m = \text{weight}(A_1)$ , since  $B_m \in \text{cl}_p(A_1)$ . This proves the claim that

$$\max\{\text{weight}(B_i) + m - i \mid i = 1, \dots, m\} \leq \text{weight}(A_1). \quad \square$$

**Corollary 4.14.** *Let  $D = (G_0 \Rightarrow G_1 \Rightarrow G_2 \Rightarrow \dots \Rightarrow G_i \Rightarrow \dots)$  be an SLD-derivation via the leftmost selection rule. Then for every goal  $G_i$  in  $D$ :  $|G_i| \leq \text{weight}(G_0)$ .*

**Proof.** By induction on  $i$ . The induction basis is provided by Lemma 4.12, the induction step by Lemma 4.13.  $\square$

So  $\text{weight}(G_0)$  is indeed the desired maximum length of goals occurring in any SLD-derivation of  $P \cup \{G_0\}$ .

We now present a formalization of the “being a variant of” relation on resultants. Our presentation here is more general than needed for the completeness proof for the equality checks. However, we need these results in full generality to prove the completeness of the subsumption checks and the context checks.



**Definition 4.15.** Let  $X$  be a set of variables. We define the relation  $\sim_X$  on resultants as  $R_1 \sim_X R_2$  if for some renaming  $\rho$ ,  $R_1\rho = R_2$  and for every  $x \in X$ ,  $x\rho = x$ . Now let  $G$  be a goal and let  $k \geq 1$ . Then the relation  $\sim_{X,G,k}$  stands for the restriction of the relation  $\sim_X$  to resultants  $S_1 \leftarrow S_2$  such that  $\leftarrow S_1$  is an instance of  $G$  and  $|\leftarrow S_2| \leq k$ .

**Lemma 4.16.** *For every set of variables  $X$ , goal  $G$  and  $k \geq 1$ ,  $\sim_{X,G,k}$  is an equivalence relation.*

For a resultant  $R$ , the equivalence class of  $R$  w.r.t. the relation  $\sim_{X,G,k}$  will be denoted as  $[R]_{X,G,k}$ , or just  $[R]$  whenever  $X$ ,  $G$  and  $k$  are clear from the context. The following lemma is crucial for our considerations.

**Lemma 4.17.** *Suppose that the language  $L$  has no function symbols and finitely many predicate symbols and constants. Then for every finite set of variables  $X$ , goal  $G$  and  $k \geq 1$ , the relation  $\sim_{X,G,k}$  has only finitely many equivalence classes.*

We can now prove the desired theorem.

**Theorem 4.18.** *The loop check  $\text{EVR}_L$  is complete w.r.t. the leftmost selection rule for function-free restricted programs.*

**Proof.** Let  $P$  be a function-free restricted program and let  $G_0$  be a goal in  $L_P$ . Let  $k = \text{weight}(G_0)$ . Consider an infinite SLD-derivation  $D = (G_0 \Rightarrow_{C_1, \theta_1} G_1 \Rightarrow \dots \Rightarrow G_{i-1} \Rightarrow_{C_i, \theta_i} G_i \Rightarrow \dots)$  of  $P \cup \{G_0\}$ . By Corollary 4.14, for every  $i \geq 0$ ,  $|G_i| \leq k$ . Every goal  $G_i$  is a goal in  $L_P$  and hence every resultant  $G_0\theta_1 \dots \theta_i \leftarrow G_i$  belongs to an equivalence class of  $\sim_{\emptyset, G_0, k}$ . Since  $L_P$  satisfies the conditions of Lemma 4.17,  $\sim_{\emptyset, G_0, k}$  has only finitely many equivalence classes, so for some  $i \geq 0$  and  $j > i$ ,  $G_0\theta_1 \dots \theta_i \leftarrow G_i$  and  $G_0\theta_1 \dots \theta_j \leftarrow G_j$  are variants. This implies that  $D$  is pruned by  $\text{EVR}_L$ .  $\square$

**Corollary 4.19** (Equality completeness). *All equality checks are complete w.r.t. the leftmost selection rule for function-free restricted programs.*

**Proof.** By Theorem 4.18 and the Relative strength Theorem 3.9.  $\square$

Now combining Corollary 3.6 and Corollary 3.7 with the Equality soundness Corollary 4.7 and the Equality completeness Corollary 4.19, we conclude that all equality checks lead to an implementation of CWA for function-free restricted programs. Moreover, a depth-first interpreter augmented by any of the equality checks based on resultants yields an implementation of query processing for these programs.

## 5. Subsumption checks

As already stated, there are eight subsumption checks. We shall define them by means of two parametrized definitions, again trusting that the reader is willing to understand our notation. The inclusion relation between goals regarded as lists is denoted by  $\subseteq_L$ ; similarly  $\subseteq_M$  for multisets. Note:  $L_1 \subseteq_L L_2$  if all elements of  $L_1$  occur in the same order in  $L_2$ ; they need not to occur on adjacent positions. For example,  $(a, c) \subseteq_L (a, b, c)$ .

### 5.1. Definitions

**Definition 5.1** (*Subsumption checks for goals*). For  $Type \in \{L, M\}$ , the *Subsumes Variant/Instance of Goal<sub>Type</sub>* check is the set of SLD-derivations

$$\begin{aligned} \text{SVG/SIG}_{Type} = \text{RemSub}(\{D \mid D = (G_0 \Rightarrow_{C_1, \theta_1} G_1 \Rightarrow \cdots \Rightarrow G_{k-1} \Rightarrow_{C_k, \theta_k} G_k) \\ \text{such that for some } i, 0 \leq i < k, \text{ there is a} \\ \text{renaming/substitution } \tau \text{ with} \\ G_k \supseteq_{Type} G_i \tau\}). \end{aligned}$$

**Definition 5.2** (*Subsumption checks for resultants*). For  $Type \in \{L, M\}$ , the *Subsumes Variant/Instance of Resultant<sub>Type</sub>* check is the set of SLD-derivations

$$\begin{aligned} \text{SVR/SIR}_{Type} = \text{RemSub}(\{D \mid D = (G_0 \Rightarrow_{C_1, \theta_1} G_1 \Rightarrow \cdots \Rightarrow G_{k-1} \Rightarrow_{C_k, \theta_k} G_k) \\ \text{such that for some } i, 0 \leq i < k, \text{ there is a renaming/substitution } \tau \text{ with } G_k \supseteq_{Type} G_i \tau \text{ and} \\ G_0 \theta_1 \dots \theta_k = G_0 \theta_1 \dots \theta_i \tau\}). \end{aligned}$$

**Lemma 5.3.** *All subsumption checks are simple loop checks.*

The following example shows the differences between the behavior of various subsumption checks and the equality checks.

**Example 5.4.** Let

$$P = \{A(y) \leftarrow A(0), C(y). \quad (C1),$$

$$A(0) \leftarrow. \quad (C2),$$

$$B(1) \leftarrow. \quad (C3),$$

$$C(z) \leftarrow B(z), A(w). \quad (C4)\},$$

and let  $G = \leftarrow A(x)$ .

Figure 7 shows an SLD-tree of  $P \cup \{G\}$  using the leftmost selection rule. It also shows how this tree is pruned by different loop checks. First we explain the behavior of the loop checks with respect to this tree. Then we shall make some generalizing comments on this behavior. In this example, the distinction between list versus multiset based loop checks does not play a role.

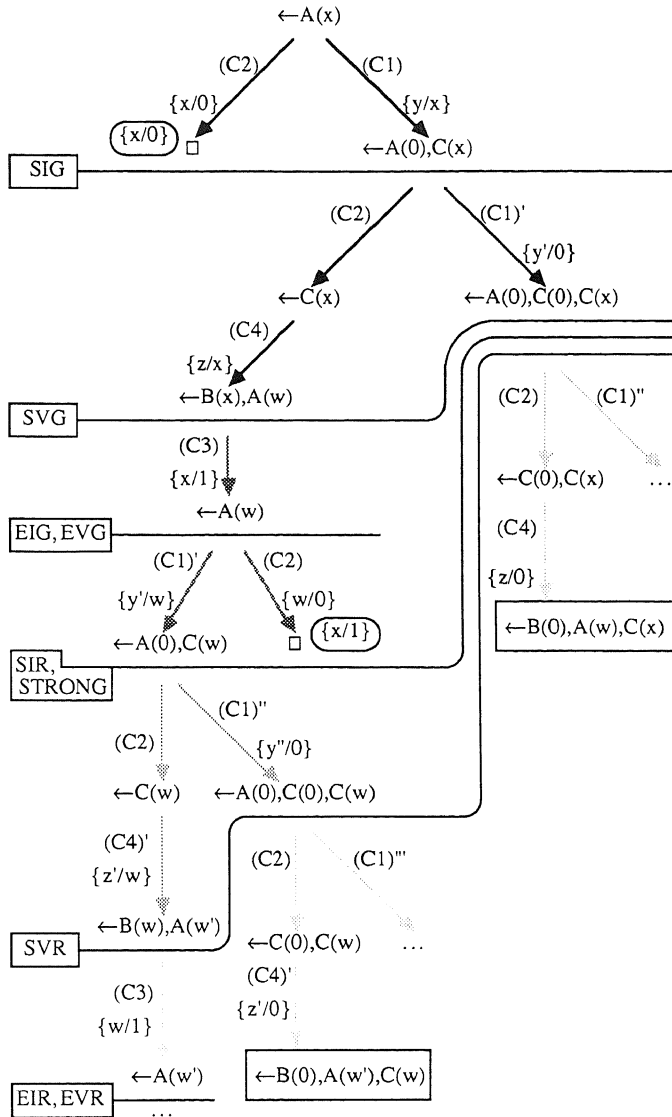

Fig. 7

Starting at the root, the first loop check that prunes the tree is the SIG check. It prunes the goal  $\leftarrow A(0), C(x)$ , because it contains  $A(0)$ , an instance of  $A(x)$ . Following the leftmost infinite branch two steps down, the SVG check prunes the goal  $\leftarrow B(x), A(w)$ , because it contains  $A(w)$ , a variant of  $A(x)$ . One step later, the atom  $B(x)$  is resolved, so the EIG and EVG checks prune the goal  $\leftarrow A(w)$  for the same reason.

However, the loop checks based on resultants do not yet prune the tree. The computed answer substitution built up so far maps  $x$  to  $x$  after the first three steps

and to 1 later on. This is clearly different from the substitutions  $\{x/0\}$  and  $\{x/w\}$ , which are used to show that  $A(0)$  resp.  $A(w)$  are an instance resp. a variant of  $A(x)$ .

Now the derivation repeats itself, but with  $x$  replaced by  $w$ . Therefore the loop checks based on resultants prune the tree during this second phase, exactly in the place where the corresponding loop checks based on goals pruned during the first phase.

The side branch that is obtained by repeatedly applying the first clause (and corresponding side branches later on) is pruned by the subsumption checks at the goal  $\leftarrow A(0), C(0), C(x)$ . This goal contains the previous goal  $\leftarrow A(0), C(x)$ . Therefore both the resultant based and the goal based loop checks prune this goal. In contrast, the equality checks do not prune this infinite branch because the goals in it become longer in every derivation step (analogously to Example 4.8).

The loop checks based on goals all prune the solution  $\{x/1\}$ , so they are not sound. Among these loop checks, the SIG check prunes as soon as possible for a weakly sound loop check. Conversely, the SIR check prunes this tree as soon as possible for a shortening loop check. So on this tree, it behaves exactly like STRONG, which exhibits such a behavior by definition.

Another example shows that there can be a nontrivial difference between the behavior of subsumption checks based on list subsumption and those based on multiset subsumption.

**Example 5.5.** Let  $P = \{A(x) \leftarrow A(y), S(x), T(y)\}$ . (Note the similarity between this clause and the clause  $A(x) \leftarrow A(y), S(y, x)$  in Theorem 3.10.) Let  $G = \leftarrow A(x_0), B(x_0)$ . An SLD-derivation (and SLD-tree) of  $P \cup \{G\}$  via the leftmost selection rule is depicted in Fig. 8. This infinite SLD-derivation is pruned by the  $\text{SVR}_M$  check at the goal  $\leftarrow A(x_2), S(x_1), T(x_2), S(x_0), T(x_1), B(x_0)$ , since a variant of an earlier goal, namely  $(\leftarrow A(x_1), S(x_0), T(x_1), B(x_0))\{x_1/x_2\}$ , is “multiset-contained” in it.

However, this derivation is *not* pruned by the  $\text{SVR}_L$  check, nor by the stronger  $\text{SIG}_L$  check. For, assume that the  $\text{SIG}_L$  check prunes this derivation at the goal

$$G_k = \leftarrow A(x_k), S(x_{k-1}), T(x_k), S(x_{k-2}), T(x_{k-1}), \dots, S(x_0), T(x_1), B(x_0),$$

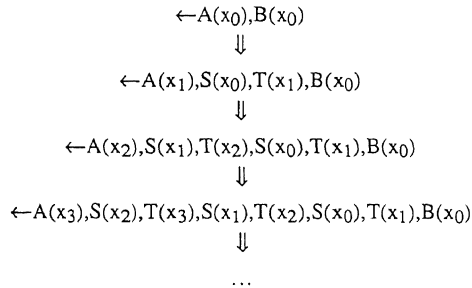

Fig. 8

because an instance of an earlier goal  $G_i$ ,

$$G_i\tau = (\leftarrow A(x_i), S(x_{i-1}), T(x_i), S(x_{i-2}), T(x_{i-1}), \dots, S(x_0), T(x_1), B(x_0))\tau,$$

is list-contained in it.

Clearly, the presence of the  $B$ -atoms in  $G_i\tau$  and  $G_k$  requires  $x_0\tau = x_0$ . So the atom  $S(x_0)\tau$  in  $G_i\tau$  corresponds to the atom  $S(x_0)$  in  $G_k$ . Then, because  $G_i\tau$  is list-contained in  $G_k$ ,  $T(x_1)\tau$  can only correspond to  $T(x_1)$ , the only atom between  $S(x_0)$  and  $B(x_0)$ . Therefore  $x_1\tau = x_1$ . Using induction, we can derive  $x_2\tau = x_2, \dots, x_i\tau = x_i$ . However, the presence of the  $A$ -atoms in  $G_i\tau$  and  $G_k$  requires  $x_i\tau = x_k$ . Since  $i < k$ , this is a contradiction. So the assumption that the  $SIG_L$  check prunes the derivation is refuted.

The above examples suggest some “stronger than” relationships (although an example can only prove the absence of such a relationship). Figure 9 shows the relationships between the subsumption checks, the equality checks, VA and IA. The arrows between the “cubes” mean that every subsumption check is stronger than the corresponding equality check in the other “cube”. So the structure of “stronger

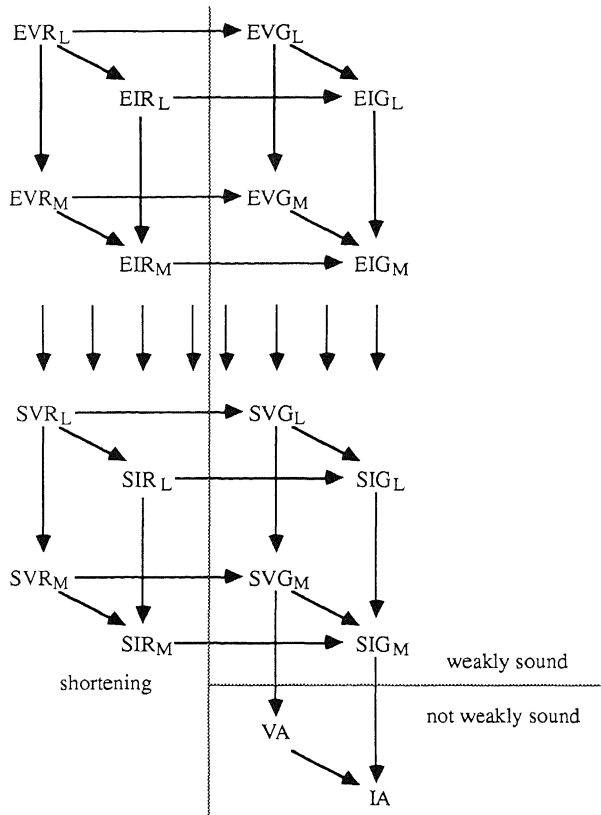

Fig. 9

than” relations between equality checks and subsumption checks is a four-dimensional hypercube. Again, proving these “stronger than” relations is straightforward.

## 5.2. Soundness

To prove the desired soundness results, we prove that the  $\text{SIR}_M$  check is shortening and that the  $\text{SIG}_M$  check is weakly sound, since these are the strongest loop checks based on resultants, respectively goals, in our scheme. First we need the following lemma.

**Lemma 5.6.** *Let  $P$  be a program and  $\tau$  a substitution. Let  $G_1$  and  $G_2$  be goals such that  $G_2\tau \subseteq_M G_1$ . Suppose  $D_1$  is an SLD-derivation of  $P \cup \{G_1\}$  with computed answer substitution  $\sigma_1$ . Then there exists an SLD-derivation  $D_2$  of  $P \cup \{G_2\}$  with a computed answer substitution  $\sigma_2$  such that  $|D_2| \leq |D_1|$  and  $\sigma_2 \leq \tau\sigma_1$ .*

**Proof.** Let  $D = (G_1 \Rightarrow_{C_1, \theta_1} \dots \Rightarrow_{C_n, \theta_n} \square)$  and let  $C_{n_1}, \dots, C_{n_m}$  be those clauses from  $C_1, \dots, C_n$  that are used (directly or indirectly) to resolve atoms belonging to  $G_2\tau$ , with  $1 \leq n_1 < \dots < n_m \leq n$ . Then there exists an unrestricted (in the sense of [16]) SLD-derivation

$$G_2\tau\theta_1 \dots \theta_{n_1-1} \Rightarrow_{C_{n_1}, \theta_{n_1} \dots \theta_{n_2-1}} \dots \Rightarrow_{C_{n_m}, \theta_{n_m} \dots \theta_n} \square$$

Now apply the mgu lemma and the lifting lemma of [16].  $\square$

We can now prove the desired theorem.

**Theorem 5.7.** (i) *The  $\text{SIR}_M$  check is shortening.*

(ii) *The  $\text{SIG}_M$  check is weakly sound.*

**Proof.** Let  $P$  be a program,  $G_0$  a goal and

$$D = (G_0 \Rightarrow_{C_1, \theta_1} G_1 \Rightarrow \dots \Rightarrow G_{i-1} \Rightarrow_{C_i, \theta_i} G_i \Rightarrow \dots \Rightarrow G_{k-1} \\ \Rightarrow_{C_k, \theta_k} G_k \Rightarrow \dots \Rightarrow_{C_m, \theta_m} \square)$$

an SLD-derivation of  $P \cup \{G_0\}$  (where  $0 \leq i < k \leq m$ ).

(i) Assume that for some substitution  $\tau$ :  $G_k \supseteq_M G_i\tau$  and  $G_0\theta_1 \dots \theta_k = G_0\theta_1 \dots \theta_i\tau$ . Then since  $G_k \Rightarrow_{C_{k+1}, \theta_{k+1}} \dots \Rightarrow_{C_m, \theta_m} \square$ , by Lemma 5.6 an SLD-derivation  $G_i \Rightarrow_{\sigma_1} \dots \Rightarrow_{\sigma_n} \square$  of  $P \cup \{G_i\}$  exists, with  $\sigma_1 \dots \sigma_n \leq \tau\theta_{k+1} \dots \theta_m$  ( $n \leq m - k < m - i$ ).

$$G_0\theta_1 \dots \theta_i\sigma_1 \dots \sigma_n \leq G_0\theta_1 \dots \theta_i\tau\theta_{k+1} \dots \theta_m = G_0\theta_1 \dots \theta_k\theta_{k+1} \dots \theta_m,$$

hence the full condition of Lemma 4.5 is satisfied, so  $\text{SIR}_M$  is shortening.

(ii) The additional condition  $G_0\theta_1 \dots \theta_k = G_0\theta_1 \dots \theta_i\tau$  was only used to prove the additional shortening condition of Lemma 4.5.  $\square$

**Corollary 5.8** (Subsumption soundness). (i) *All subsumption checks based on resultants are shortening. A fortiori they are sound.*

(ii) *All subsumption checks based on goals are weakly sound.*

**Proof.** By Theorem 5.7 and the Relative strength Theorem 3.9.  $\square$

### 5.3. Completeness

We now shift our attention to completeness issues. From the results of the previous section we can immediately deduce the following result.

**Corollary 5.9** (Subsumption completeness 1). *All subsumption checks are complete w.r.t. the leftmost selection rule for function-free restricted programs.*

**Proof.** By the Equality completeness Corollary 4.19 and the Relative strength Theorem 3.9.  $\square$

However, the subsumption checks are stronger than the corresponding equality checks. So we can try to find other classes of programs for which the subsumption checks are complete. We know that the subsumption checks are not complete for all programs, not even for all function-free programs. For  $P = \{A(x) \leftarrow A(y), S(y, x)\}$ , a derivation of  $P \cup \{\leftarrow A(x), B(x)\}$  is not pruned by any of the subsumption checks, as was shown in Theorem 3.10.

A close analysis of the proof of this theorem shows that the problem is caused by three “events” occurring simultaneously:

(1) A new variable  $y$  is introduced by a “recursive” atom,  $A(y)$ .

(2) There is a relation between this new variable  $y$  and an old variable  $x$ , namely via the atom  $S(y, x)$ .

(3) The “recursive” atom  $A(y)$  is selected before the “relating” atom  $S(y, x)$ .

It appears that, in order to obtain the completeness of the subsumption checks, it is enough to prevent any of these events. Clearly, the use of restricted programs and the leftmost selection rule prevents the third event. We now introduce two new classes of programs, preventing the first and the second event, respectively.

**Definition 5.10** (*Nvi program*). A clause  $C$  is *nonvariable introducing* (in short *nvi*) if every variable that appears in the body of  $C$  also appears in the head of  $C$ . A program  $P$  is *nvi* if every clause in  $P$  is *nvi*.

**Definition 5.11** (*Svo program*). A clause  $C$  has the *single variable occurrence* property (in short *is svo*) if, in the body of  $C$ , no variable occurs more than once. A program  $P$  is *svo* if every clause in  $P$  is *svo*.

Clearly, in nvi programs the first event cannot occur, whereas in svo programs the second event is prevented. We would rather have used the terminology *right-linear* instead of svo, which is common in the area of term rewriting systems. However, in the area of deductive databases this term is already in use for a completely different notion.

**Example 5.12.** The following program is an nvi program and an svo program, but not a restricted program. It computes in the relation *add* the sum of two two-digit binary numbers (the first four arguments of *add*); this sum is a three-digit binary number, stored in the last three arguments of *add*.

$$\begin{aligned} \text{ADD} = \{ & \text{add}(0,0, A,B, 0,A,B) \leftarrow. \\ & \text{add}(A,B, 0,0, 0,A,B) \leftarrow. \\ & \text{add}(A,B, A,B, A,B,0) \leftarrow. \\ & \text{add}(A_1,B_1, A_2,B_2, C,A_3,B_3) \leftarrow \text{add}(0,B_1, 0,B_2, 0,0,B_3), \\ & \qquad \qquad \qquad \text{add}(0,A_1, 0,A_2, 0,C,A_3). \\ & \text{add}(A_1,1, A_2,1, 1,0,0) \leftarrow \text{add}(0,A_1, 0,A_2, 0,0,1).\} \end{aligned}$$

The first three clauses are evidently correct; every addition of the form  $0X + 0Y$  is taken care of by them. The fourth clause deals with the case where adding the last digits of both numbers does not give a carry (ensured by the first atom in the body). The fifth clause deals with the case where there is such a carry. Only the case  $A_1 \neq A_2$  (or equivalently,  $A_1 + A_2 = 1$ ) has to be considered there: if  $A_1 = A_2$  then the third clause applies.

Note that this program yields infinite derivations that are not pruned by any of the equality checks. Indeed, starting with the goal  $\leftarrow \text{add}(0,B_1, 0,B_2, 0,0,B_3)$ , the first recursive clause applies, giving the goal  $\leftarrow \text{add}(0,B_1, 0,B_2, 0,0,B_3), \text{add}(0,0, 0,0, 0,0,0)$ . Repeatedly selecting  $\text{add}(0,B_1, 0,B_2, 0,0,B_3)$  and applying the first recursive clause yields an infinite derivation containing goals of increasing length, which is not pruned by any of the equality checks.

We now prove that the weakest of the subsumption checks, the  $\text{SVR}_L$  check, is complete for function-free nvi programs. To this end we use the following (weakened) version of Kruskal's Tree Theorem, called Higman's Lemma. (See [12]; for a formulation of the full version of Kruskal's Tree Theorem, see [9] or [14].)

**Lemma 5.13** (Higman's Lemma). *Let  $w_0, w_1, w_2, \dots$  be an infinite sequence of (finite) words over a finite alphabet  $\Sigma$ . Then for some  $i$  and  $k > i$ ,  $w_i \subseteq_L w_k$ .*

In order to prove that the  $\text{SVR}_L$  check is complete for function-free nvi programs, we prove that, in the absence of function symbols, infinite derivations in which no new variables are introduced are pruned by the  $\text{SVR}_L$  check. Then we prove that every derivation of a function-free nvi program (and an arbitrary goal) has a variant that indeed does not introduce new variables.



**Definition 5.14.** An SLD-derivation  $D = (G_0 \Rightarrow_{C_1, \theta_1} G_1 \Rightarrow \dots)$  is *nonvariable introducing* (in short *nvi*) if  $\text{var}(G_0) \supseteq \text{var}(G_1) \supseteq \text{var}(G_2) \supseteq \dots$ .

**Lemma 5.15.** *In the absence of function symbols, every infinite nvi SLD-derivation is pruned by  $\text{SVR}_L$ .*

**Proof.** Let  $D = (G_0 \Rightarrow_{C_1, \theta_1} G_1 \Rightarrow \dots)$  be an infinite nvi SLD-derivation. We take for  $\Sigma$  the set of equivalence classes of  $\sim_{\text{var}(G_0), G_0, 1}$  as defined in Definition 4.15. By Lemma 4.17,  $\Sigma$  is finite. To apply Higman's Lemma 5.13 we represent for  $j \geq 0$  a goal  $G_j = \leftarrow A_{1j}, \dots, A_{n_jj}$  (or rather the corresponding resultant  $G_0 \theta_1 \dots \theta_j \leftarrow G_j$ ) as the word  $[G_0 \theta_1 \dots \theta_j \leftarrow A_{1j}], \dots, [G_0 \theta_1 \dots \theta_j \leftarrow A_{n_jj}]$  over  $\Sigma$ . (Recall that for a resultant  $R$ ,  $[R]$  denotes its equivalence class.) The sequence of representations of  $G_0, G_1, G_2, \dots$  yields an infinite sequence of words  $w_0, w_1, w_2, \dots$  over  $\Sigma$ .

Now by Higman's Lemma 5.13, for some  $j$  and  $k > j$ :

$$\begin{aligned} & [G_0 \theta_1 \dots \theta_j \leftarrow A_{1j}], \dots, [G_0 \theta_1 \dots \theta_j \leftarrow A_{n_jj}] \\ & \subseteq_L [G_0 \theta_1 \dots \theta_k \leftarrow A_{1k}], \dots, [G_0 \theta_1 \dots \theta_k \leftarrow A_{n_kk}]. \end{aligned}$$

So by the definition of  $\sim_{\text{var}(G_0), G_0, 1}$ , there exist renamings  $\rho_1, \dots, \rho_{n_j}$  which do not act on the variables of  $G_0$  such that

$$\begin{aligned} & (G_0 \theta_1 \dots \theta_j \leftarrow A_{1j})\rho_1, \dots, (G_0 \theta_1 \dots \theta_j \leftarrow A_{n_jj})\rho_{n_j} \\ & \subseteq_L (G_0 \theta_1 \dots \theta_k \leftarrow A_{1k}), \dots, (G_0 \theta_1 \dots \theta_k \leftarrow A_{n_kk}). \end{aligned}$$

However,  $D$  is nvi, so  $\text{var}(G_j) \subseteq \text{var}(G_0)$  and therefore the renamings  $\rho_h$  do not act on the atoms  $A_{ij}$  of  $G_j$  ( $1 \leq h, i \leq n_j$ ). Thus  $G_j = G_j \rho_1 \subseteq_L G_k$  and  $G_0 \theta_1 \dots \theta_j \rho_1 = G_0 \theta_1 \dots \theta_k$ . So  $D$  is pruned by  $\text{SVR}_L$ .  $\square$

**Lemma 5.16.** *Let  $P$  be a function-free nvi program and let  $G_0$  be a goal in  $L_P$ . Let  $D$  be an infinite SLD-derivation of  $P \cup \{G_0\}$ . Then a variant  $D'$  of  $D$  is an infinite nvi derivation.*

**Proof.** Suppose that  $D = (G_0 \Rightarrow_{C_1, \theta_1} G_1 \Rightarrow_{C_2, \theta_2} G_2 \Rightarrow \dots)$ . We show that there exists an infinite nvi derivation  $D' = (G'_0 \Rightarrow_{C_1, \theta'_1} G'_1 \Rightarrow_{C_2, \theta'_2} G'_2 \Rightarrow \dots)$  that is a variant of  $D$ . Note that  $D'$  uses the same input clauses as  $D$ .

We give an inductive construction of  $D'$ . By definition,  $G'_0 = G_0$ . Suppose we have constructed  $D'$  up to a goal  $G'_{i-1}$  ( $i > 0$ ).  $G'_{i-1}$  and  $G_{i-1}$  are variants, say  $G_{i-1} = G'_{i-1} \rho$ .  $G'_0 = G_0$  and the clauses  $C_1, \dots, C_{i-1}$  are the same as in  $D$ , so  $C_i$  is well standardized apart and we may assume that  $C_i \rho = C_i$ . Therefore  $\rho \theta_i \rho^{-1}$  is an applicable (idempotent) mgu.

Now we obtain  $\theta'_i$  by replacing every pure variable binding  $x/y$  within  $\rho \theta_i \rho^{-1}$  by  $y/x$  whenever  $x \in \text{var}(G'_{i-1})$  and  $y \in \text{var}(C_i)$ , and replacing for such  $x$  and  $y$  every other binding  $z/y$  within  $\rho \theta_i \rho^{-1}$  by  $z/x$ .

Since no function symbols appear in  $P$ , this yields that for every variable  $x \in \text{var}(G'_{i-1})$  either  $x\theta'_i \in \text{var}(G'_{i-1})$  or  $x\theta'_i$  is a constant. Hence  $\text{var}(G'_{i-1}\theta'_i) \subseteq \text{var}(G'_{i-1})$ . Now let  $A$  be the selected atom in  $G'_{i-1}$ , let  $R$  be the rest of  $G'_{i-1}$  and let  $x \in \text{var}(G'_i)$ . Two cases arise.

(1)  $x$  is introduced by  $C_i$ , that is  $x \in \text{var}(\text{body}(C_i)\theta'_i)$ . Then, since  $P$  is an nvi program,  $x \in \text{var}(\text{head}(C_i)\theta'_i)$ .  $\theta'_i$  is a unifier of  $\text{head}(C_i)$  and  $A$ , so  $x \in \text{var}(A\theta'_i) \subseteq \text{var}(G_{i-1}\theta'_i) \subseteq \text{var}(G'_{i-1})$ .

(2)  $x$  is introduced by  $G'_{i-1}$ , that is  $x \in \text{var}(R\theta'_i)$ . Then  $x \in \text{var}(G'_{i-1}\theta'_i) \subseteq \text{var}(G'_{i-1})$ . This proves the induction hypothesis for  $D'$  up to the goal  $G'_i$ .  $\square$

**Theorem 5.17.** *The  $\text{SVR}_L$  loop check is complete for function-free nvi programs.*

**Proof.** By Lemmas 5.3, 5.15 and 5.16.  $\square$

**Corollary 5.18** (Subsumption completeness 2). *All subsumption checks are complete for function-free nvi programs.*

**Proof.** By Theorem 5.17 and the Relative strength Theorem 3.9.  $\square$

We now prove that the  $\text{SVR}_L$  check (and hence all subsumption checks) are complete for function-free svo programs. By a construction similar to the one used in the proof of Lemma 5.16, we may assume that in an SLD-derivation  $D = (G_0 \Rightarrow_{C_1, \theta_1} G_1 \Rightarrow \dots)$ ,  $\text{var}(G_0\theta_i) \subseteq \text{var}(G_0)$  for  $i > 0$ . (Note that for this construction, only the absence of function symbols was needed, and not the nvi property.) Under this assumption we can prove the following lemma.

**Lemma 5.19.** *Let  $P$  be a function-free svo program and let  $G_0$  be a goal in  $L_P$ . Let  $D = (G_0 \Rightarrow_{C_1, \theta_1} G_1 \Rightarrow_{C_2, \theta_2} G_2 \Rightarrow \dots)$  be an SLD-derivation of  $P \cup \{G_0\}$ . Then for every goal  $G_i$  ( $i \geq 0$ ), if  $x$  occurs more than once in  $G_i$ , then  $x \in \text{var}(G_0)$ .*

**Proof.** By induction. For  $i = 0$ , the claim is trivial. Now suppose  $x$  occurs more than once in  $G_{i+1}$  ( $i \geq 0$ ) and  $x \notin \text{var}(G_0)$ .

Let  $G_i = (A, S)$ , where  $A$  is the selected atom (not necessarily the leftmost atom) and let  $C_{i+1} = H \leftarrow X$ . Then  $\theta_{i+1}$  is an idempotent mgu of  $A$  and  $H$  and  $G_{i+1} = (X, S)\theta_{i+1}$ . There are two ways in which we can obtain a variable  $x$  occurring more than once in  $G_{i+1}$ .

(1) A variable  $y$  occurs more than once in  $(X, S)$  and  $y\theta_{i+1} = x$ . By standardizing apart,  $\text{var}(S) \cap \text{var}(X) = \emptyset$ , so  $y$  occurs either only in  $S$  or only in  $X$ . Since  $C_{i+1}$  is svo,  $y$  does not occur more than once in  $X$ . Therefore  $y$  occurs more than once in  $S$ . Then by the induction hypothesis,  $y \in \text{var}(G_0)$ . So  $x = y\theta_{i+1} \in \text{var}(G_0\theta_{i+1}) \subseteq \text{var}(G_0)$ .

(2) There are two variables  $y_1$  and  $y_2$  in  $(X, S)$  such that  $y_1\theta_{i+1} = y_2\theta_{i+1} = x$  and  $y_1 \neq y_2$ . In this case  $y_1, y_2 \in \text{var}(A, H)$ , since  $\text{dom}(\theta_{i+1}) \subseteq \text{var}(A, H)$ . If  $y_1 \in \text{var}(S)$ , then by standardizing apart  $y_1 \notin \text{var}(H)$ , so  $y_1 \in \text{var}(A)$ . Therefore  $y_1$  occurs more than once in  $G_i$  (in  $A$  and in  $S$ ), and we can apply the induction hypothesis again. Since the same argument holds for  $y_2 \in \text{var}(S)$ , only the case  $y_1, y_2 \in \text{var}(X)$  is left. In this case, since  $y_1, y_2 \in \text{var}(A, H)$ , by standardizing apart,  $y_1, y_2 \in \text{var}(H)$ .

Since  $y_1\theta_{i+1} = y_2\theta_{i+1} = x$ , the sets  $Z_1 = \{z \in \text{var}(A) \mid z \text{ occurs in } A \text{ at the position of an occurrence of } y_1 \text{ in } H\}$  and  $Z_2 = \{z \in \text{var}(A) \mid z \text{ occurs in } A \text{ at the position of an occurrence of } y_2 \text{ in } H\}$  are not disjoint. (Otherwise, a more general unifier of  $A$  and  $H$  than  $\theta_{i+1}$  would exist, mapping  $y_1$  to an element of  $Z_1$  and  $y_2$  to an element of  $Z_2$ .) Let  $z \in Z_1 \cap Z_2$ . Then  $z$  occurs at least twice in  $A$ , so  $z \in \text{var}(G_0)$ . Thus  $x = z\theta_{i+1} \in \text{var}(G_0\theta_{i+1}) \subseteq \text{var}(G_0)$ .  $\square$

We can now prove the desired theorem.

**Theorem 5.20.** *The  $\text{SVR}_L$  loop check is complete for function-free svo programs.*

**Proof.** Let  $P$  be a function-free svo program and let  $G_0$  be a goal in  $L_P$ . Let  $D = (G_0 \Rightarrow_{C_1, \theta_1} G_1 \Rightarrow_{C_2, \theta_2} G_2 \Rightarrow \dots)$  be an infinite SLD-derivation of  $P \cup \{G_0\}$ .

Again, we take for  $\Sigma$  the set of equivalence classes of  $\sim_{\text{var}(G_0), G_0, 1}$  as defined in Definition 4.15. By Lemma 4.17,  $\Sigma$  is finite. To apply Higman's Lemma 5.13 we represent a goal  $G_j = A_{1j}, \dots, A_{n_jj}$  in  $D$  as the word  $w_j = [G_0\theta_1 \dots \theta_j \leftarrow A_{1j}], \dots, [G_0\theta_1 \dots \theta_j \leftarrow A_{n_jj}]$  over  $\Sigma$ . The sequence of representations of  $G_0, G_1, G_2, \dots$  yields an infinite sequence of words  $w_0, w_1, w_2, \dots$  over  $\Sigma$ .

Now by Higman's Lemma 5.13, for some  $j$  and  $k > j$ ,

$$\begin{aligned} & [G_0\theta_1 \dots \theta_j \leftarrow A_{1j}], \dots, [G_0\theta_1 \dots \theta_j \leftarrow A_{n_jj}] \\ & \subseteq_L [G_0\theta_1 \dots \theta_k \leftarrow A_{1k}], \dots, [G_0\theta_1 \dots \theta_k \leftarrow A_{n_kk}]. \end{aligned}$$

So there are renamings  $\rho_1, \dots, \rho_{n_j}$  such that

$$\begin{aligned} & (G_0\theta_1 \dots \theta_j \leftarrow A_{1j})\rho_1, \dots, (G_0\theta_1 \dots \theta_j \leftarrow A_{n_jj})\rho_{n_j} \\ & \subseteq_L (G_0\theta_1 \dots \theta_k \leftarrow A_{1k}), \dots, (G_0\theta_1 \dots \theta_k \leftarrow A_{n_kk}). \end{aligned}$$

We now construct a renaming  $\rho$ . Consider the set  $X = \text{var}(G_j) - \text{var}(G_0)$ . By Lemma 5.19 a variable  $x \in X$  occurs at most once in  $G_j$ ; if  $x$  occurs in  $A_{ij}$ , then we define  $x\rho = x\rho_i$ . In order to make  $\rho$  a renaming  $\rho$  maps (one-to-one) the variables of  $X\rho - X$  to the variables of  $X - X\rho$ ;  $\rho$  is the identity mapping on variables outside  $X \cup X\rho$ . Since, by the definition of  $\sim_{\text{var}(G_0), G_0, 1}$ , the renamings  $\rho_i$  do not act on variables in  $\text{var}(G_0)$ ,  $x \in X \cup X\rho$  implies  $x \notin \text{var}(G_0)$ . Hence  $\rho$  does not act on the variables in  $\text{var}(G_0)$ , so  $G_j\rho \subseteq_L G_k$ . From the assumption  $\text{var}(G_0\theta_i) \subseteq \text{var}(G_0)$  for  $i > 0$  it follows that  $\text{var}(G_0\theta_1 \dots \theta_j) \subseteq \text{var}(G_0)$ , thus  $G_0\theta_1 \dots \theta_j\rho = G_0\theta_1 \dots \theta_j$ . So  $G_j\rho \subseteq_L G_k$  and  $G_0\theta_1 \dots \theta_j\rho = G_0\theta_1 \dots \theta_k$ , hence  $D$  is pruned by  $\text{SVR}_L$ .  $\square$

**Corollary 5.21** (Subsumption completeness 3). *All subsumption checks are complete for function-free svo programs.*

**Proof.** By Theorem 5.20 and the Relative strength Theorem 3.9.  $\square$

Now combining Corollaries 3.6 and 3.7 with the Subsumption soundness Corollary 5.8 and the Subsumption completeness Corollaries 5.9, 5.18 and 5.21, we conclude that all subsumption checks lead to an implementation of CWA for restricted programs, nvi programs and svo programs without function symbols. Moreover, the subsumption checks based on resultants also lead to an implementation of query processing for these programs.

## 6. Context checks

The Instance of Atom check is not weakly sound due to the fact that it does not take into account the context of an atom. However, whereas  $A(x)$  and  $A(y)$  differ only by a renaming, the existence of a refutation of  $\leftarrow A(y), B(x)$  does not imply the existence of a refutation of  $\leftarrow A(x), B(x)$ . To remedy this problem we should keep track of the links between the variables in the atom and those in the rest of the goal.

Roughly speaking, the IA check prunes a derivation as soon as a goal  $G_k$  occurs that contains an instance  $A\tau$  of an atom  $A$  that occurred in an earlier goal  $G_i$ . But when a variable occurs both inside and outside of  $A$  in  $G_i$ , we should not prune the derivation if this link has been altered. Such a variable  $x$  in  $G_i$  is substituted by  $x\theta_{i+1} \dots \theta_k$  when  $G_k$  is reached. Therefore  $\tau$  and  $\theta_{i+1} \dots \theta_k$  should agree on  $x$ . This leads us to a loop check introduced by [3].

### 6.1. Definitions

**Definition 6.1** (*Context checks for goals*). The *Variant/Instance Context check on Goals* is the set of SLD-derivations

$$\text{CVG/CIG} = \text{RemSub}(\{D \mid D = (G_0 \Rightarrow_{C_1, \theta_1} G_1 \Rightarrow \dots \Rightarrow G_{k-1} \Rightarrow_{C_k, \theta_k} G_k) \\ \text{such that for some } i \text{ and } j, 0 \leq i < j < k, \text{ there is a} \\ \text{renaming/substitution } \tau \text{ such that for some atom} \\ A \text{ in } G_i: A\tau \text{ appears in } G_k \text{ as the result of} \\ \text{resolving } A\theta_{i+1} \dots \theta_j \text{ in } G_j \text{ and for every variable} \\ x \text{ that occurs both inside and outside of } A \text{ in } G_i, \\ x\theta_{i+1} \dots \theta_k = x\tau\}).$$

Besnard describes the condition on the substitutions as follows: “When  $A\tau$  is substituted for  $A\theta_{i+1} \dots \theta_k$  in  $G_i\theta_{i+1} \dots \theta_k$ , this should give an instance of  $G_i$ .” We

show that this formulation is equivalent to ours. Let  $G_i = (A, S)$ , that is  $A$  occurs in  $G_i$  and  $S$  is the list of other atoms in  $G_i$ . Then  $(A\tau, S\theta_{i+1} \dots \theta_k)$  should be an instance of  $(A, S)$ , say  $(A\sigma, S\sigma)$ . Clearly,

$$x\sigma = \begin{cases} x\tau & \text{for } x \in \text{var}(A) \\ x\theta_{i+1} \dots \theta_k & \text{for } x \in \text{var}(S), \end{cases}$$

so for  $x \in \text{var}(A) \cap \text{var}(S)$ ,  $x\tau = x\theta_{i+1} \dots \theta_k$ .

The following example clarifies the use of the context checks.

**Example 6.2.** We use the program  $P$  and the goal  $G$  of Variant of Atom check Example 2.5 and apply the CIG check on two SLD-trees of  $P \cup \{G\}$ , via the leftmost and rightmost selection rule, respectively. This yields the trees in Fig. 10.

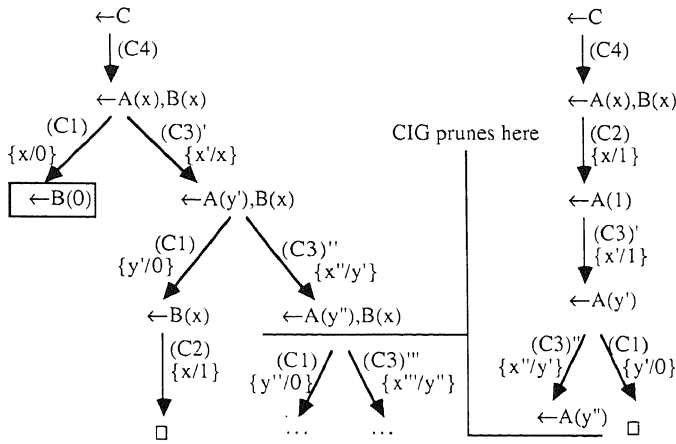

Fig. 10

The goal  $G_3 = \leftarrow A(y')$  in the rightmost tree that was incorrectly pruned by the VA check, is not pruned by the CIG check. Certainly,  $A(y')$  is the result of resolving  $A(1)$  in  $G_2$ , the further instantiated version of  $A(x)$  in  $G_1$ . But replacing  $A(x)\theta_2\theta_3$  by  $A(y')$  in  $G_1\theta_2\theta_3$  yields  $\leftarrow A(y'), B(1)$ , which is *not* an instance of  $\leftarrow A(x), B(x)$ .

**Claim 6.3.** CVG and CIG are weakly sound simple loop checks.

**Proof.** Proving that CVG and CIG are simple loop checks is straightforward. Besnard claims that CIG is weakly sound. From this it follows that the weaker CVG check is also weakly sound. See also Corollary 6.7.  $\square$

In Example 4.3, the context checks act exactly in the same way as the corresponding equality checks. This shows that CVG and CIG are not sound. Again we can obtain sound, even shortening, versions by using resultants instead of goals.

**Definition 6.4** (*Context checks for resultants*). The *Variant/Instance Context check on Resultants* is the set of SLD-derivations

$$\text{CVR/CIR} = \text{RemSub}(\{D \mid D = (G_0 \Rightarrow_{C_1, \theta_1} G_1 \Rightarrow \cdots \Rightarrow G_{k-1} \Rightarrow_{C_k, \theta_k} G_k) \\ \text{such that for some } i \text{ and } j, 0 \leq i \leq j < k, \text{ there is a} \\ \text{renaming/substitution } \tau \text{ such that } G_0 \theta_1 \dots \theta_k = \\ G_0 \theta_1 \dots \theta_i \tau \text{ and for some atom } A \text{ in } G_i: A\tau \\ \text{appears in } G_k \text{ as the result of resolving} \\ A\theta_{i+1} \dots \theta_j \text{ in } G_j \text{ and for every variable } x \text{ that} \\ \text{occurs both inside and outside of } A \text{ in} \\ G_i: x\theta_{i+1} \dots \theta_k = x\tau\}).$$

Using Besnard's phrasing, the conditions on the substitutions can be summarized as: "When  $A\tau$  is substituted for  $A\theta_{i+1} \dots \theta_k$  in the resultant  $R_i\theta_{i+1} \dots \theta_k$ , this should give an instance of  $R_i$ ."

**Lemma 6.5.** *CVR and CIR are simple loop checks.*

## 6.2. Soundness

Now we prove that the CIR check is shortening. From this it follows that the weaker loop check CVR is also shortening.

**Theorem 6.6.** *The CIR check is shortening.*

**Proof.** Let  $P$  be a program,  $G_0$  a goal and  $D = (G_0 \Rightarrow_{C_1, \theta_1} G_1 \Rightarrow \cdots \Rightarrow G_{i-1} \Rightarrow_{C_i, \theta_i} G_i \Rightarrow \cdots \Rightarrow G_{k-1} \Rightarrow_{C_k, \theta_k} G_k \Rightarrow \cdots \Rightarrow_{C_m, \theta_m} \square)$  an SLD-derivation of  $P \cup \{G_0\}$  (where  $0 \leq i < k \leq m$ ).

Assume that  $D$  is pruned by CIR, that is for some substitution  $\tau: G_i = \leftarrow(A, S_i)$ ,  $G_k = \leftarrow(A\tau, S_k)$ ,  $A\tau$  descends from  $A$ ,  $S_i\theta_{i+1} \dots \theta_k = S_i\tau$  and  $G_0\theta_1 \dots \theta_k = G_0\theta_1 \dots \theta_i\tau$ . (Here  $G = \leftarrow(A, S)$  means:  $A$  occurs in  $G$  and  $S$  is obtained by removing  $A$  from  $G$ .)

Then  $\leftarrow S_i \subseteq_M G_i$  and  $\leftarrow A\tau \subseteq_M G_k$ . Since

$$G_i \Rightarrow_{C_{i+1}, \theta_{i+1}} \cdots \Rightarrow_{C_k, \theta_k} G_k \Rightarrow_{C_{k+1}, \theta_{k+1}} \cdots \Rightarrow_{C_m, \theta_m} \square,$$

by Lemma 5.6 we have SLD-refutations  $D_1$  of  $P \cup \{\leftarrow S_i\}$  and  $D_2$  of  $P \cup \{\leftarrow A\}$ , where the computed answer substitution of  $D_1$ ,  $\tau_1 \leq \theta_{i+1} \dots \theta_m$  and the computed answer substitution of  $D_2$ ,  $\tau_2 \leq \tau\theta_{k+1} \dots \theta_m$ . Say  $\tau_2\gamma = \tau\theta_{k+1} \dots \theta_m$ . Now we combine  $D_1$  and  $D_2$  into an unrestricted SLD-refutation of  $P \cup \{\leftarrow(A, S_i)\}$ : first resolve  $A$  as in  $D_2$ ; the goal  $S_i\tau_2$  remains. Replacing the last mgu  $\mu$  of this derivation by  $\mu\gamma$ , this remaining goal becomes

$$S_i\tau_2\gamma = S_i\tau\theta_{k+1} \dots \theta_m = S_i\theta_{i+1} \dots \theta_k\theta_{k+1} \dots \theta_m.$$

From Lemma 8.5 of [16] and the existence of  $D_1$  it follows that  $P \cup \{\leftarrow S, \theta_{i+1} \dots \theta_m\}$  can be refuted indeed, giving a computed answer substitution  $\varepsilon$ . The mgu lemma of [16] shows that the combined unrestricted refutation can be turned into a real SLD-refutation  $D_3$  of  $P \cup \{\leftarrow (A, S_i)\}$  giving a computed answer substitution  $\tau_3 \leq \tau_2 \gamma \varepsilon = \tau \theta_{k+1} \dots \theta_m$ . Therefore

$$G_0 \theta_1 \dots \theta_i \tau_3 \leq G_0 \theta_1 \dots \theta_i \tau \theta_{k+1} \dots \theta_m = G_0 \theta_1 \dots \theta_k \theta_{k+1} \dots \theta_m.$$

Since  $A\tau$  descends from  $A$ , an inspection of the proof of Lemma 5.6 shows that every derivation step in  $D_1$  and  $D_2$  has a corresponding derivation step in the tail ( $G_i \Rightarrow \dots \Rightarrow \square$ ) of  $D$ . This tail consists of  $m - i$  derivation steps. On the other hand, at least one step in this tail has no corresponding step in  $D_1$  or  $D_2$ : the step in which  $A\theta_{i+1} \dots \theta_j$  is selected. Hence the number of derivation steps in  $D_3$  (which equals the number of derivation steps in  $D_1$  and  $D_2$  together) is smaller than  $m - i$ . Now, apply Lemma 4.5.  $\square$

**Corollary 6.7** (Context soundness). (i) *The context checks based on resultants are shortening. A fortiori they are sound.*

(ii) *The context checks based on goals are weakly sound.*

**Proof.** By Theorem 6.6 and the Relative strength Theorem 3.9. Note that omitting the considerations about computed answer substitutions from this proof yields a proof for (ii), i.e. for Claim 6.3.  $\square$

For derivations via certain selection rules (including leftmost and rightmost selection rule), a much easier soundness proof exists, based on the relative strength of the context checks.

**Definition 6.8.** (This definition is equivalent to the definition of local selection functions in [23].) A selection rule  $R$  is *local* if every SLD-derivation  $D = (G_0 \Rightarrow_{C_1, \theta_1} G_1 \Rightarrow \dots)$  via  $R$  satisfies the following property. If in a goal  $G_i$ , an atom  $A$  is selected and in a goal  $G_j$  ( $j > i$ ) the further instantiated version  $B\theta_{i+1} \dots \theta_j$  of the atom  $B$  in  $G_i$  is selected, then  $A$  is resolved completely between  $G_i$  and  $G_j$ .

**Lemma 6.9.** *The SIG<sub>L</sub> check is stronger than the CIG check and the SIR<sub>L</sub> check is stronger than the CIR check w.r.t. local selection rules.*

**Proof.** Suppose  $D = (G_0 \Rightarrow_{C_1, \theta_1} G_1 \Rightarrow \dots \Rightarrow_{C_k, \theta_k} G_k)$  is pruned at  $G_k$  by the CIG check, see Fig. 11. We show that  $D$  is pruned by the SIG<sub>L</sub> check at  $G_k$  (or earlier).

We have an atom  $A$  in  $G_i$ ,  $A\theta_{i+1} \dots \theta_j$  in  $G_j$  as the selected atom and  $A\tau$  as the result of resolving  $A\theta_{i+1} \dots \theta_j$ . Let  $G_i = (A, S, T)$ , where  $S$  consists of those atoms in  $G_i$  that are completely resolved between  $G_i$  and  $G_j$ . The use of a local selection rule yields

$$G_j = (A\theta_{i+1} \dots \theta_j, T\theta_{i+1} \dots \theta_j) \quad \text{and} \quad G_k = (A\tau, U, T\theta_{i+1} \dots \theta_k)$$

( $U$  consists of the other atoms in  $G_k$  that are the result of resolving  $A\theta_{i+1} \dots \theta_j$ ). Finally, if  $x \in \text{var}(A) \cap \text{var}(S, T)$  then  $x\theta_{i+1} \dots \theta_k = x\tau$ .

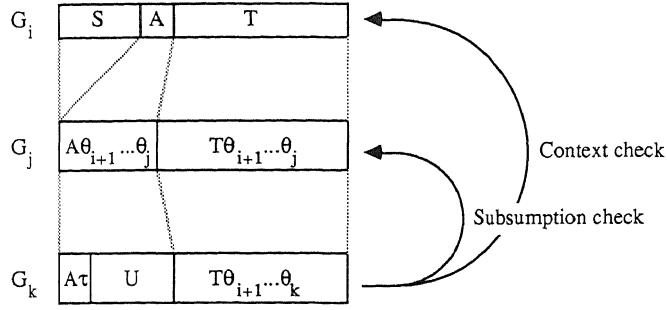

Fig. 11

We show that for some substitution  $\sigma$ ,  $G_j\sigma \subseteq_L G_k$ . We define  $\sigma$  as follows:

$$x\sigma = \begin{cases} x & \text{if } x \notin \text{var}(G_j) \\ x\theta_{j+1} \dots \theta_k & \text{if } x \in \text{var}(G_j) - \text{var}(A), \\ x\tau & \text{if } x \in \text{var}(G_j) \cap \text{var}(A). \end{cases}$$

We show that (i)  $A\theta_{i+1} \dots \theta_j\sigma = A\tau$  and that (ii)  $T\theta_{i+1} \dots \theta_j\sigma = T\theta_{i+1} \dots \theta_k$ .

(i) Let  $x \in \text{var}(A)$ , then  $x \in \text{var}(G_i)$ . We prove that  $x\theta_{i+1} \dots \theta_j\sigma = x\tau$ .

If  $x \in \text{var}(G_j)$ , then  $x\theta_{i+1} \dots \theta_j = x$ , hence  $x\theta_{i+1} \dots \theta_j\sigma = x\sigma = x\tau$ .

If  $x \notin \text{var}(G_j)$  then  $x\theta_{i+1} \dots \theta_j \neq x$ , hence  $x \in \text{var}(S)$ . So  $x\theta_{i+1} \dots \theta_k = x\tau$ . Moreover, for every  $y \in \text{var}(x\theta_{i+1} \dots \theta_j)$ , either  $y \in \text{var}(S)$  or  $y$  is introduced by  $C_{i+1}, \dots, C_j$ , i.e.  $y \notin \text{var}(G_i)$ , in particular  $y \notin \text{var}(A)$ . In both cases  $y\sigma = y\theta_{j+1} \dots \theta_k$  (notice that  $y \in \text{var}(x\theta_{i+1} \dots \theta_j) \subseteq \text{var}(A\theta_{i+1} \dots \theta_j) \subseteq \text{var}(G_j)$ ). So  $x\theta_{i+1} \dots \theta_j\sigma = x\theta_{i+1} \dots \theta_k = x\tau$ .

(ii) Now let  $y \in \text{var}(T\theta_{i+1} \dots \theta_j)$ . We prove that  $y\sigma = y\theta_{j+1} \dots \theta_k$ . First note that for some  $x \in \text{var}(T)$ :  $y \in \text{var}(x\theta_{i+1} \dots \theta_j)$ .

If  $x \notin \text{var}(S)$ , then  $x = x\theta_{i+1} \dots \theta_j = y$ , so  $y \in \text{var}(T)$ , hence  $y\sigma = y\theta_{j+1} \dots \theta_k$ .

If  $x \in \text{var}(S)$ , then again either  $y \in \text{var}(S)$  or  $y \notin \text{var}(A)$ , and in both cases  $y\sigma = y\theta_{j+1} \dots \theta_k$ .

If  $D$  is pruned by the CIR check, then we also have that  $G_0\theta_1 \dots \theta_k = G_0\theta_1 \dots \theta_i\tau$ . We show that this implies  $G_0\theta_1 \dots \theta_k = G_0\theta_1 \dots \theta_j\sigma$ , i.e. that  $D$  is pruned by the  $\text{SIR}_L$  check. Let  $x \in \text{var}(G_0\theta_1 \dots \theta_i)$ , hence  $x\theta_{i+1} \dots \theta_k = x\tau$ . We show that  $x\theta_{i+1} \dots \theta_j\sigma = x\theta_{i+1} \dots \theta_k$ .

If  $x \notin \text{var}(S)$ , then  $x\theta_{i+1} \dots \theta_j = x$ , hence

$$x\theta_{i+1} \dots \theta_j\sigma = x\sigma = \begin{cases} x = x\theta_{i+1} \dots \theta_j = x\theta_{i+1} \dots \theta_k & \text{if } x \notin \text{var}(G_j), \\ x\theta_{j+1} \dots \theta_k = x\theta_{i+1} \dots \theta_k & \text{if } x \in \text{var}(G_j) - \text{var}(A), \\ x\tau = x\theta_{i+1} \dots \theta_k & \text{if } x \in \text{var}(G_j) \cap \text{var}(A). \end{cases}$$

If  $x \in \text{var}(S)$ , then again for every  $y \in \text{var}(x\theta_{i+1} \dots \theta_j)$ , either  $y \in \text{var}(S)$  or  $y \notin \text{var}(A)$ , and in both cases  $y\sigma = y\theta_{j+1} \dots \theta_k$  (if  $y \notin \text{var}(G_j)$  then  $y\sigma = y = y\theta_{j+1} \dots \theta_k$ ). So  $x\theta_{i+1} \dots \theta_j\sigma = x\theta_{i+1} \dots \theta_k$ .  $\square$

The following example shows that the previous result does not hold for selection rules that are not local.



**Example 6.10** (Based on Example 10 in [3]). Let

$$P = \{ \underline{A} \leftarrow B. \quad (C1), \\ B \leftarrow A. \quad (C2), \\ C \leftarrow D. \quad (C3) \},$$

and let  $G = \leftarrow A, C$ .

Then the derivation  $\leftarrow \underline{A}, C \Rightarrow_{(C1)} \leftarrow B, C \Rightarrow_{(C3)} \leftarrow B, D \Rightarrow_{(C2)} \leftarrow A, D$  (in which the selected atoms are underlined) is pruned by the context checks (the  $A$  in the fourth goal is the result of resolving the  $A$  in the first goal), but not by the subsumption checks.

Now we can add the context checks to our “stronger than” scheme, as in Fig. 12. The dotted arrows are only valid for local selection rules.

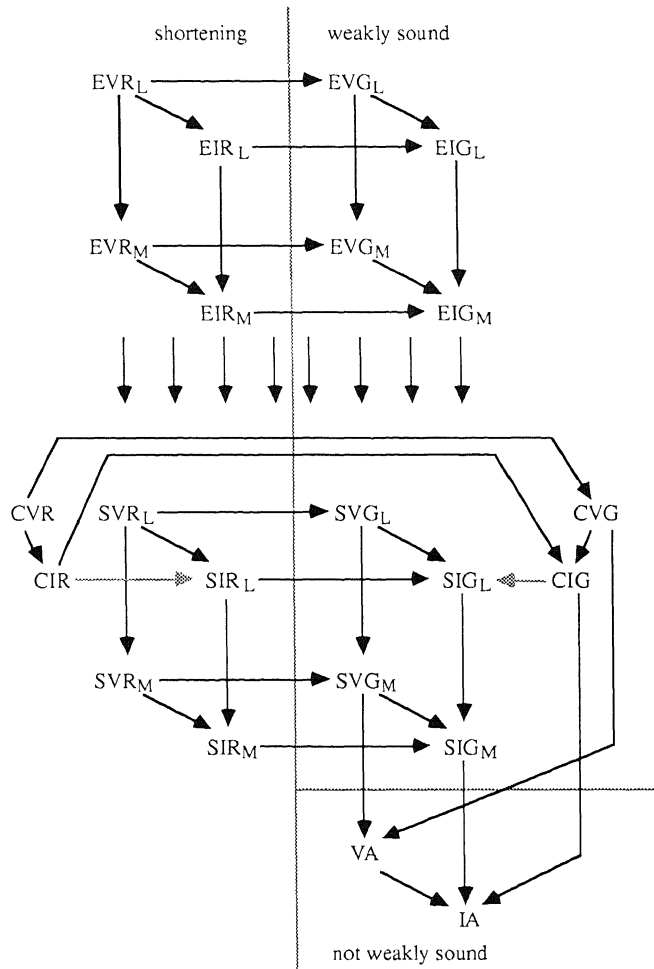

Fig. 12

### 6.3. Completeness

Again we shift our attention to completeness issues. We first prove that, like the equality checks and the subsumption checks, the context checks are complete w.r.t. the leftmost selection rule for function-free restricted programs.

**Theorem 6.11.** *The CVR check is complete w.r.t. the leftmost selection rule for function-free restricted programs.*

**Proof.** Let  $P$  be a function-free restricted program and let  $G_0$  be a goal in  $L_P$ . Let  $k = \text{weight}(G_0)$ . Consider an infinite SLD-derivation  $D = (G_0 \Rightarrow_{C_1, \theta_1} G_1 \Rightarrow \dots \Rightarrow G_{i-1} \Rightarrow_{C_i, \theta_i} G_i \Rightarrow \dots)$  of  $P \cup \{G_0\}$ . By Corollary 4.14 for every  $i \geq 0$ :  $|G_i| \leq k$ . Every goal  $G_i$  is a goal in  $L_P$  and hence every resultant  $G_0\theta_1 \dots \theta_i \leftarrow G_i$  belongs to an equivalence class of  $\sim_{\emptyset, G_0, k}$ .  $L_P$  satisfies the conditions of Lemma 4.17, so  $\sim_{\emptyset, G_0, k}$  has only finitely many equivalence classes. Thus the set  $E = \{\underline{e} \mid \underline{e} \text{ is an equivalence class of } \sim_{\emptyset, G_0, k} \text{ and for infinitely many resultants } R \text{ in } D: R \in \underline{e}\}$  is nonempty. For simplicity, we shall say that the goal  $G_i$  is in an equivalence class  $\underline{e}$ , when in fact  $(G_0\theta_1 \dots \theta_i \leftarrow G_i) \in \underline{e}$ .

For every equivalence class  $\underline{e}$  of  $\sim_{\emptyset, G_0, k}$ , we define the length of  $\underline{e}$ , denoted by  $|\underline{e}|$ , as the length of the goals in  $\underline{e}$ . Since  $E \neq \emptyset$ , we can define  $l = \min\{|\underline{e}| \mid \underline{e} \in E\}$ . Now we choose an equivalence class  $e \in E$  with  $|e| = l$ . According to the choice of  $e$ ,  $D$  contains infinitely many goals in  $e$  and a finite number of shorter goals (since the number of equivalence classes of  $\sim_{\emptyset, G_0, k}$  is finite).

Let  $G_i$  and  $G_k$  be (the first) two goals in  $D$  that are in  $e$  such that no goal lying in  $D$  between them is shorter. Since  $G_i$  and  $G_k$  are in the same equivalence class  $e$ , we have  $G_k = G_i\tau$  and  $G_0\theta_1 \dots \theta_k = G_0\theta_1 \dots \theta_i\tau$  for some renaming  $\tau$ .

Let  $A$  be the leftmost atom in  $G_i$  and let  $S$  be the rest of  $G_i$ .  $A$  is selected in  $G_i$ . However,  $A$  is not completely resolved between  $G_i$  and  $G_k$ , otherwise a goal shorter than  $G_i$ , namely an instance of  $S$ , would appear between  $G_i$  and  $G_k$  in  $D$ . Therefore the atom  $A\tau$  in  $G_k$  is the result of resolving  $A$ . Furthermore, no atom of  $S$  is selected between  $G_i$  and  $G_k$ , so  $G_k = (A\tau, S\theta_{i+1} \dots \theta_k)$ . Hence  $S\theta_{i+1} \dots \theta_k = S\tau$ .

When in the resultant  $R_i\theta_{i+1} \dots \theta_k$ , we replace  $A\theta_{i+1} \dots \theta_k$  by  $A\tau$ , we obtain  $(G_0\theta_1 \dots \theta_k \leftarrow A\tau, S\theta_{i+1} \dots \theta_k) = (G_0\theta_1 \dots \theta_i\tau \leftarrow A\tau, S\tau)$ , which is a variant of  $R_i$ . Therefore  $D$  is pruned by the CVR check.  $\square$

**Corollary 6.12** (Context completeness 1). *All context checks are complete w.r.t. the leftmost selection rule for function-free restricted programs.*

**Proof.** By Theorem 6.11 and the Relative strength Theorem 3.9.  $\square$

Besnard [3] claims without much proof that the CIG check is complete for function-free nvi programs. It appears that even the weakest of the four context checks, CVR, is complete for function-free nvi programs.

**Theorem 6.13.** *The CVR check is complete for function-free nvi programs.*

**Proof.** Let  $P$  be an nvi program,  $G_0$  a goal in  $L_P$  and  $D = (G_0 \Rightarrow_{c_1, \theta_1} G_1 \Rightarrow_{c_2, \theta_2} G_2 \Rightarrow \dots)$  an infinite SLD-derivation of  $P \cup \{G_0\}$ . By Lemma 5.16 we may assume that  $D$  is an nvi derivation.

Since  $D$  is infinite, at least one atom in  $G_0$  has infinitely many selected descendants, hence the proof tree of this atom is infinite. Applying König's Lemma on this proof tree shows that it has an infinite branch, so there exists an infinite sequence of goals  $G_{m_0}, G_{m_1}, \dots$  ( $0 \leq m_0 < m_1 < \dots$ ) containing atoms  $A_0, A_1, \dots$  such that for every  $i \geq 0$ ,

- (1)  $A_i$  is the selected atom in  $G_{m_i}$ ,
- (2)  $A_{i+1}$  is (the further instantiated version of) an atom  $A'_{i+1}$  which is introduced in  $G_{m_{i+1}}$  as the result of resolving  $A_i$ .

The situation is depicted in Fig. 13 (selected atoms are underlined).

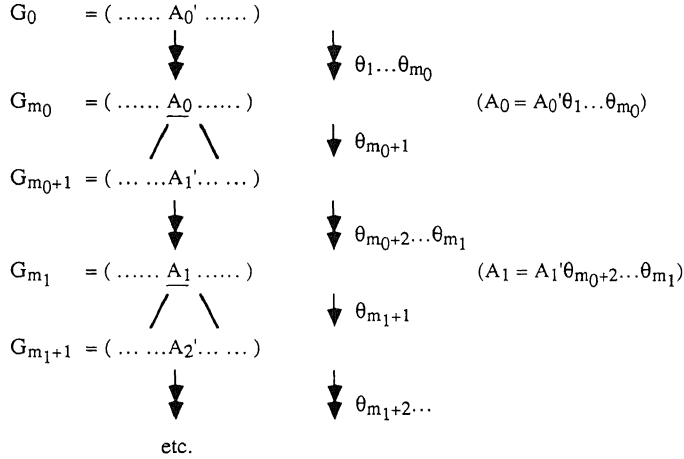

Fig. 13

We now consider the resultants  $G_0 \theta_1 \theta_2 \dots \theta_{m_i} \leftarrow A_i$  ( $i \geq 0$ ). These resultants belong to equivalence classes of the relation  $\sim_{\text{var}(G_0), G_0, 1}$  (see Definition 4.15), which has by Lemma 4.17 only finitely many equivalence classes. Hence for some  $p$  and  $q > p$ :  $(G_0 \theta_1 \theta_2 \dots \theta_{m_p} \leftarrow A_p) \sim_{\text{var}(G_0), G_0, 1} (G_0 \theta_1 \theta_2 \dots \theta_{m_q} \leftarrow A_q)$ . So by Definition 4.15, there exists a renaming  $\rho$  such that

- (1)  $G_0 \theta_1 \theta_2 \dots \theta_{m_p} \rho = G_0 \theta_1 \theta_2 \dots \theta_{m_q}$ ,
- (2)  $A_p \rho = A_q$ ,
- (3)  $\rho$  does not act on the variables of  $G_0$ .

When this is compared with the definition of the CVR check, taking  $i = j = m_p$ ,  $k = m_q$ ,  $A = A_p$  and  $\tau = \rho$ , it appears that the only additional condition for pruning is that “for every variable  $x$  that occurs both inside and outside of  $A_p$  in  $G_{m_p}$ :  $x \theta_{m_p+1} \dots \theta_{m_q} = x \rho$ ”. We now prove that this condition is also satisfied, which proves that  $D$  is pruned by the CVR check.

First observe that, since  $D$  is nvi,  $\text{var}(G_{m_p}) \subseteq \text{var}(G_0)$ , so for every variable  $x$  in  $G_{m_p}$ ,  $x\rho = x$ . In particular, it follows that  $A_q = A_p\rho = A_p$ .

Now suppose that  $x$  occurs both inside and outside of  $A_p$  in  $G_{m_p}$ . Then  $x$  occurs in  $A_q$ , hence in  $G_{m_q}$ . Thus  $x$  occurs in every goal between  $G_{m_p}$  and  $G_{m_q}$ . Suppose (in order to obtain a contradiction with the previous observation) that for some  $\theta_n$  among  $\theta_{m_p+1}, \dots, \theta_{m_q}$ ,  $x\theta_n \neq x$ . Since  $P$  is function-free,  $x\theta_n$  is then either a constant or a variable other than  $x$ . Furthermore,  $\theta_n$  is idempotent, hence  $\theta_n$  does not contain a binding  $y/x$ . Therefore  $x \notin \text{var}(\text{VAR}\theta_n)$ , in particular  $x \notin \text{var}(G_n)$ : contradiction. Hence  $x\theta_{m_p+1} \dots \theta_{m_q} = x = x\rho$ .  $\square$

**Corollary 6.14** (Context completeness 2). *All context checks are complete for function-free nvi programs.*

**Proof.** By Theorem 6.13 and the Relative strength Theorem 3.9.  $\square$

Now combining Corollary 3.6 and Corollary 3.7 with the Context soundness Corollary 6.7 and the Context completeness Corollaries 6.12, 6.14 and 6.16, we conclude that all context checks lead to an implementation of CWA for restricted programs, nvi programs and svo programs without function symbols. Moreover, the context checks based on resultants also lead to an implementation of query processing for these programs.

## References

- [1] K.R. Apt, R.N. Bol and J.W. Klop, On the safe termination of PROLOG programs, in: G. Levi and M. Martelli eds., *Proc. 6th Internat. Conf. on Logic Programming* (MIT Press, Cambridge MA, 1989) 353–368.
- [2] K.R. Apt and M.H. van Emden, Contributions to the theory of logic programming, *J. ACM* **29** (1982) 841–862.
- [3] Ph. Besnard, On infinite loops in logic programming, Internal Report 488, IRISA, Rennes, 1989.
- [4] D.R. Brough and A. Walker, Some practical properties of logic programming interpreters, in: *Proc. Internat. Conf. on 5th Generation Computer Systems* (1984) 149–156.
- [5] K.L. Clark, Negation as failure, in: H. Gallaire and J. Minker eds., *Logic and Data Bases* (Plenum Press, New York, 1978) 293–322.
- [6] C.L. Chang and R.C. Lee, *Symbolic Logic and Mechanical Theorem Proving* (Academic Press, New York, 1973).
- [7] W. Clocksin and C. Mellish, *Programming in PROLOG* (Springer, New York, 1981).
- [8] M.A. Covington, Eliminating unwanted loops in PROLOG, *SIGPLAN Notices* **20** (1985) 20–26.
- [9] N. Dershowitz, A note on simplification orderings, *Inform. Process. Lett.* **9** (1979) 212–215.
- [10] A. van Gelder, Efficient loop detection in PROLOG using the tortoise-and-hare technique, *J. Logic Programming* **4** (1987) 23–31.
- [11] A. van Gelder, Negation as failure using tight derivations for general logic programs, in: J. Minker ed., *Foundations of Deductive Databases and Logic Programming* (Morgan Kaufmann, Los Altos, 1988) 149–176.
- [12] G. Higman, Ordering by divisibility in abstract algebra's, in: *Proc. London Math. Soc.* (3) **2** (7) (1952) 215–221.
- [13] J.W. Klop and J.J. Ch. Meyer, Toegepaste logica deel I: Resolutie-logica, Course Notes, Free University of Amsterdam, 1988 (in Dutch).

- [14] J.B. Kruskal, Well-quasi-ordering, the tree theorem, and Vazsonyi's conjecture, *Trans. Amer. Math. Soc.* **95** (1960) 210-225.
- [15] K. Kunen, Some remarks on the completed database, in: R. Kowalski and K. Bowen eds., *Proc. 5th Internat. Conf. on Logic Programming* (MIT Press, Cambridge MA, 1988) 978-992.
- [16] J.W. Lloyd, *Foundations of Logic Programming* (Springer, Berlin, 2nd ed., 1987).
- [17] J.W. Lloyd and J.C. Shepherdson, Partial evaluation in logic programming, Technical Report CS-87-09, Dept. of Computer Science, University of Bristol, 1987.
- [18] D. Poole and R. Goebel, On eliminating loops in PROLOG, *SIGPLAN Notices* **8** (1985) 38-40.
- [19] R. Reiter, On closed world data bases, in: H. Gallaire and J. Minker eds., *Logic and Data Bases* (Plenum Press, New York, 1978) 55-76.
- [20] D.E. Smith, M.R. Genesereth and M.L. Ginsberg, Controlling recursive inference, *Artificial Intelligence* **30** (1986) 343-389.
- [21] H. Seki and H. Itoh, A query evaluation method for stratified programs under the extended CWA, in: R. Kowalski and K. Bowen eds., *Proc. 5th Internat. Conf. on Logic Programming* (MIT Press, Cambridge MA, 1988) 195-211.
- [22] O. Štěpánková and P. Štěpánek, A complete class of restricted logic programs, in: F.R. Drake and J.K. Truss eds., *Logic Colloquium '86* (North Holland, Amsterdam, 1988) 319-324.
- [23] L. Vieille, Resursive query processing: The power of logic, *Theoret. Comput. Sci.* **69** (1989) 1-53.